

Ingest and Production Server

# R&S<sup>®</sup> VENICE 2U

Hardware Guide

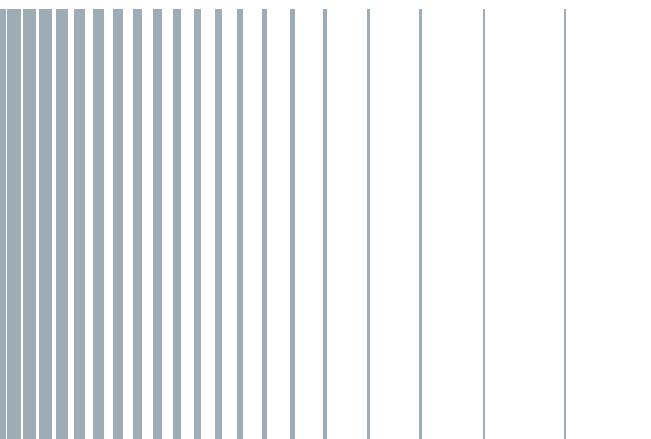





Hardware Guide Version 1.2 for VENICE 2U Hardware Version 1.2

Copyright © 2014 by Rohde & Schwarz DVS GmbH, Hanover. All rights reserved.

The manuals as well as the soft- and/or hardware described here and all their constituent parts are protected by copyright. Without the express permission of Rohde & Schwarz DVS GmbH any form of use which goes beyond the narrow bounds prescribed by copyright legislation is prohibited and liable to prosecution.

This particularly applies to duplication, copying, translation, processing, evaluation, publishing, and storing and/or processing in an electronic system.

Specifications and data may change without notice. We offer no guarantee that this documentation is correct and/or complete. In no event shall Rohde & Schwarz DVS GmbH be liable for any damages whatsoever (including without limitation any special, indirect or consequential damages, and damages resulting from loss of use, data or profits, or business interruption) arising out of the use of or inability to use the hardware, software and/or manual materials.

Those parts of this documentation that describe optional software or hardware features usually contain a corresponding note. Anyway, a lack of this note does not mean any commitment from Rohde & Schwarz DVS GmbH.

DVS is a registered trademark of Rohde & Schwarz DVS GmbH. Linux is a registered trademark of Linus Torvalds. LSI is a trademark or registered trademark of LSI Corporation.

Any other product names mentioned in this documentation may be trademarks or registered trademarks of their respective owners and as such are subject to the usual statutory provisions.

In this document R&S®VENICE 2U is abbreviated as VENICE 2U.



---

**Headquarter:**

Rohde & Schwarz DVS GmbH  
Krepenstr. 8  
30165 Hannover  
GERMANY

Phone: +49-511-67807-0  
Fax: +49-511-630070  
E-mail: [info.dvs@rohde-schwarz.com](mailto:info.dvs@rohde-schwarz.com)  
Internet: <http://www.dvs.de>

**Support:**

Phone: +49-511-67807-125  
Fax: +49-511-371985  
E-mail: [service.dvs@rohde-schwarz.com](mailto:service.dvs@rohde-schwarz.com)

# Contents

<b>1</b>	<b>Introduction</b> .....	1-1
1.1	Target Group .....	1-1
1.2	Conventions Used in this User Guide .....	1-1
1.3	Safety Instructions .....	1-4
1.4	Important Notes .....	1-6
<b>2</b>	<b>Overview</b> .....	2-1
2.1	R&S®VENICE 2U Models .....	2-2
2.2	Overview of the Front .....	2-6
2.2.1	The Front of the System .....	2-6
2.2.2	Operation Items .....	2-8
2.2.3	Hard Disk Array .....	2-9
2.2.4	Fan Area .....	2-11
2.3	Overview of the Rear .....	2-13
2.3.1	The Rear of the System .....	2-13
2.3.2	Digital Video I/Os .....	2-14
2.3.3	Main Connector Panel .....	2-16
2.3.4	Power Supply .....	2-19
2.3.5	ATX Connector Panel .....	2-20
2.3.6	Slot Panel Connectors .....	2-22
2.4	Battery Backup Unit .....	2-24
2.5	SNMP – Simple Network Management Protocol .....	2-25
<b>3</b>	<b>Installation</b> .....	3-1
3.1	System Setup .....	3-2
3.2	Note about the Network Installation .....	3-3
<b>4</b>	<b>Operation</b> .....	4-1
4.1	Starting the System .....	4-2
4.2	Shutting Down the System .....	4-2



<b>5</b>	<b>Maintenance</b> .....	5-1
5.1	Hard Disk Maintenance .....	5-2
5.1.1	Introduction to RAID .....	5-2
5.1.2	Identifying a Broken Hard Disk .....	5-3
5.1.3	Replacing a Hard Disk .....	5-4
5.2	Fan Maintenance .....	5-8
5.3	Power Supply Maintenance .....	5-10
5.4	Opening and Closing the Casing .....	5-12
5.4.1	Opening the Casing .....	5-12
5.4.2	Closing the Casing .....	5-13
5.5	Removal of the Faceplate .....	5-14
5.6	Backup or Recovery of the System Disk .....	5-15
5.6.1	Creating a Backup Image of the System Disk .....	5-15
5.6.2	Restoring the System Disk .....	5-17
<b>A</b>	<b>Appendix</b> .....	A-1
A.1	Troubleshooting .....	A-2
A.2	Technical Data .....	A-4
A.2.1	General Technical Data .....	A-4
A.2.2	Dimensions .....	A-5
A.3	Video Rasters .....	A-6
A.4	Signal In- and Outputs .....	A-7
A.5	Packing Instructions .....	A-10
A.6	Conformity Declarations .....	A-12
A.6.1	RoHS Compliance .....	A-12
A.6.2	EC Declaration of Conformity (CE Marking) .....	A-12
A.6.3	FCC Compliance Statement .....	A-13
A.6.4	Korea Certification .....	A-14
<b>I</b>	<b>Index</b> .....	I-1

# Introduction

## 1.1 Target Group

To use this manual you should have experience in handling video and computer equipment. Additionally, to use the R&S DVS system in connection with other equipment, e.g. a camera or a VTR, you should know how to handle this equipment.

When performing maintenance tasks on the hardware of the R&S DVS system, you must be qualified to work on, repair and test electrical equipment.

## 1.2 Conventions Used in this User Guide

The following typographical conventions will be used in this documentation:

1. Texts preceded by this symbol describe activities that you must perform in the order indicated.
  - Texts preceded by this symbol are parts of a list.
    - Texts preceded by this symbol are parts of a list of a second level.
  - Texts preceded by this symbol are parts of a requirements list.
    - ▶ Texts preceded by this symbol describe the result of an action.



Texts preceded by this symbol are general notes intended to facilitate work and help avoid errors.



### **NOTICE**

#### **Cause of Risk**

Indicates the possibility of incorrect operation which can result in damage to the product. You must pay particular attention to text that follows this symbol to avoid errors.

**Preventive measures to avoid risks of damage to the system.**



	<p><b>Source of Danger</b></p> <p>Indicates a hazardous situation which, if not avoided, could result in minor or moderate injury.</p> <p><b>Preventive measures to avoid minor or moderate injury.</b></p>
	<p><b>Source of Danger</b></p> <p>Indicates a hazardous situation which, if not avoided, can result in death or serious injury.</p> <p><b>Preventive measures to avoid death or serious injury.</b></p>
	<p><b>Source of Danger</b></p> <p>Indicates a hazardous situation which, if not avoided, will result in death or serious injury.</p> <p><b>Preventive measures to avoid death or serious injury.</b></p>

- “ ” Texts enclosed by quotation marks are references to other manuals, guides, chapters, or sections.
- ‘ ’ Texts enclosed by single quotation marks are references to labelings given by the author and quoted labelings.

<b>'Window'</b>	Text in bold with single quotation marks indicates a window name
<b>BUTTON</b>	Text in small caps and bold indicates a push button
<b><i>Group/Menu</i></b>	Text in italic and bold indicates either a group name, menu name or options in a menu list
<b><i>Menu &gt; Option</i></b>	In the specified group or menu select the stated item.
<b>Item</b>	Text in bold only stands for other labeled items of a user interface
<i>Directory/File</i>	Directory structure or file
Entry	Indicates parameters or variables, as well as selections or entries made in a program; it may also indicate a command (e.g. at a command line), a syntax or contents of a file/output
[Key]	An individual key or a key combination on a keyboard





## Keyboard Shortcuts

To perform options or procedures with the keyboard often requires a simultaneous pressing of two keys.

Example:

[Ctrl + F1]	If this is given, hold down the [Ctrl] key and press simultaneously the [F1] key.
[Alt, F1]	If this is given, press the [Alt] key first and then the key [F1] successively.

## Screenshots

The screenshots shown in this documentation may be taken on various operating systems as well as from pre-release versions of the software. Their appearance may differ from your environment. However, they should contain all relevant elements that you need to understand the described actions.



## 1.3 Safety Instructions

To use R&S®VENICE 2U correctly please heed the following:

### NOTICE

#### Disregarding the safety instructions

If the R&S DVS system is not used in compliance with the safety instructions, the warranty and all resulting liability claims will be void.

**Please read the following safety instructions carefully before attempting any installation and/or performing any work on the VENICE 2U hardware.**

### General

VENICE 2U has been built according to the applying safety regulations. To minimize the possibility of a faulty operation of the device all manuals and guides must be available at all times at the operation site. Before installing and/or using the R&S DVS system the manuals and guides delivered with it must be read and observed.

- Use the R&S DVS system only in apparent good technical order.
- The hardware of the R&S DVS system works with voltages that can be hazardous to your health. Never work on the system or access its interior with the power cable(s) being plugged in. Make sure the power supply is disconnected from the components you intend to work on.
- Computer hardware contains components that are sensitive to electrostatic discharge. If you touch them without precautionary measures, they can be destroyed. Use a wrist strap connected to ground when accessing electronic parts and take care of grounding the system. Avoid touching the internal components of the R&S DVS system whenever possible.
- Computer hardware contains components that are sensitive to changing voltages. Connecting or disconnecting the R&S DVS system to or from peripheral hardware while any of them is switched on may damage the hardware. Switch off all peripheral hardware before connecting or disconnecting anything.
- Use, store and transport the R&S DVS system only in compliance with the technical data laid out in section "Technical Data" on page A-4.
- If fluids or solid objects get inside the casing, the R&S DVS system must be disconnected from the power supply immediately. Before using the R&S DVS system again, it has to be checked by authorized service personnel.
- Only use a damp tissue without any cleaning agents to clean the casing.



- The R&S DVS system must not be misused, abused, physically damaged, neglected, exposed to fire, water or excessive changes in the climate or temperature, or operated outside maximum rating.
- Do not perform any changes or extensions to the R&S DVS system whatsoever.

### **Transportation**

VENICE 2U is a very sensitive device. Especially the hard disks of the system must be handled with great care. Therefore, observe in case of transportation:

- Handle the R&S DVS system with great care.
- Always use the original packing or a similar structured packing for transportation as detailed in section "Packing Instructions" on page A-10.
- Avoid shocks or vibrations during transport. For longer distances it is recommended to use a lifting truck.
- Keep the R&S DVS system as a transportation good dry.
- In the warranty period you have to keep the original packing and use it in case of transportation.

### **Environmental Conditions**

For error-free working and a long service life VENICE 2U needs some basic environmental conditions:

- Do not expose the R&S DVS system to sources of heat, such as direct sunlight or a radiator.
- Do not cover or obstruct the ventilation holes of the system.
- When installing the R&S DVS system in a rack, take care that warmed up air is conducted to the rear of the rack and properly vented away.
- Avoid areas with high humidity or dust. Best operating conditions are given in an air-conditioned site.
- Do not expose the R&S DVS system to strong electric or magnetic fields.
- Avoid areas where the R&S DVS system will be subject to vibrations or shocks.



## 1.4 Important Notes

The following provides information about warranty, a note about the conformity of the product and some other general information.

### Warranty Information

This product is warranted to be free of defects in materials and workmanship for a period of one year from the date of purchase. Rohde & Schwarz DVS GmbH (in short 'R&S DVS') extends this Limited Warranty to the original purchaser.

#### NOTICE

#### Incorrect packaging

This warranty will be void if you do not transport the R&S DVS device in the original packing.

**You have to keep the original packing and use it in case of transportation.**

In the event of a defect or failure to confirm to this Limited Warranty, R&S DVS will repair or replace the product without charge. In order to make a claim under this Limited Warranty, the purchaser must notify R&S DVS or their representative in writing of the product failure. In this Limited Warranty the customer must upon R&S DVS's request return the product to the place of purchase or send the defective device to a given address for the necessary repairs to be performed. In the warranty period the customer must keep the original packing and pack the R&S DVS product in it in case of a product return. If the customer is not satisfied with the repair, R&S DVS will have the option to either attempt a further repair, exchange the product or refund the purchase price.

This warranty does not cover:

- Products not developed by Rohde & Schwarz DVS GmbH.
- Products not used in compliance with the safety instructions detailed in section "Safety Instructions" on page 1-4.
- Products on which warranty stickers or product serial numbers have been removed, altered or rendered illegible.
- The costs of installations, removals, transportations, or re-installations.
- Costs for transportation damages.
- Damages caused to any other item.
- Any special, indirect or consequential damages, and damages resulting from loss of use, data or profits, or business interruption.

## Declaration of Conformity



This product has been tested according to the applying national and international directives and regulations. Further information about this can be found in section “Conformity Declarations” on page A-12.

## Product Disposal (B2B)

Used electrical and electronic products should not be disposed of with general household waste. At the end of its service life you may return the R&S DVS product after appropriate prior notification to either your local distributor or R&S DVS in Germany. R&S DVS will then take the device free of charge to a waste disposal organization which will recycle and reuse it environmental friendly.



## General Notes

Please observe the following general important notes:

### NOTICE

#### Changing settings/ re-configuring the system

VENICE 2U has been delivered to you fully preconfigured and optimized for a realtime in- and output of video streams. Changing any of the settings (e.g. the hardware, software and/or BIOS settings) may lead to a loss of performance or may even render the system unusable. Re-configuring the system anew is in most cases a lengthy procedure.

**Do not change any of the settings unless you are absolutely sure of what you are doing and what the results would be.**

### NOTICE

#### Installation of third-party software

Your R&S DVS system has been tested thoroughly and is very reliable. However, because of the vast amount of third-party software available, its reactions on the installation of such could not be tested. The installation of third-party software may disrupt the realtime capability and/or limit the functionality of your system.

**When installing third-party software, make sure that it does not interrupt and/or limit any functionality of the system.**



Only use the designated storage to store video and audio data. Other storage locations will be too slow for realtime operations.

**NOTICE****Storage capacity exceeded**

In case of a full storage performance losses may occur.

**Leave about 10 to 15% of the overall main storage capacity empty of data for performance reasons.**



Compared to other alarms sounded by the system the alarm buzzer of the power supply is relatively faint. In a loud environment it may be drowned by other noises. When operating the R&S DVS system in a loud environment, it is recommended to check the state of the alarm LED (see section "Operation Items" on page 2-8) at regular intervals.



It is recommended to set up an e-mail notification, to ensure you get informed when a hardware malfunction occurs.



# Overview

## Contents

R&S®VENICE 2U Models .....	2-2
Overview of the Front .....	2-6
The Front of the System .....	2-6
Operation Items .....	2-8
Hard Disk Array .....	2-9
Fan Area .....	2-11
Overview of the Rear .....	2-13
The Rear of the System .....	2-13
Digital Video I/Os .....	2-14
Main Connector Panel .....	2-16
Power Supply .....	2-19
ATX Connector Panel .....	2-20
Slot Panel Connectors .....	2-22
Battery Backup Unit .....	2-24
SNMP – Simple Network Management Protocol .....	2-25



## 2.1 R&S®VENICE 2U Models

The R&S®VENICE 2U system is delivered in a 2HU chassis and depending on, for example, the type of use or the workflow that is required you can order further options like e.g. the ingest option. The following options are available:

- VENICE 2U base model with playout capability (default)
- VENICE 2U with default playout capability + ingest option
- VENICE 2U with default playout capability + ingest and transform option

Functionality Option	Base Model (playout only)	Base Model + Ingest Option	Base Model + Ingest and Transform Option
<b>Basics</b>			
Available channels	2 or 4 channels	2 or 4 channels	2 or 4 channels
SDI playout	✓	✓	✓
SDI ingest	–	✓	✓
File ingest of P2/XDCAM	–	✓	✓
Transcoding	–	–	✓
Transfer via (Spycer)	✓	✓	✓
VENICE 2U Play server license	optional	✓	✓
<b>Storage</b>			
SAN (incl. Fibre Channel +HBA)	✓	✓	✓
3000 GB (excl. HBA)	optional	optional	optional
6000 GB (incl. HBA)	optional	optional	optional
9000 GB (incl. HBA)	optional	optional	optional
<b>Connectors</b>			
AES/EBU in/out	✓	✓	✓
HDMI output	optional	optional	optional
LTC output	✓	✓	✓
LTC input	–	✓	✓
<b>Control Interfaces</b>			
MOS/VDCP	✓	✓	✓
FIMS/SOAP	✓	✓	✓



Functionality Option	Base Model (playout only)	Base Model + Ingest Option	Base Model + Ingest and Transform Option
<b>Workflows</b>			
Avid workflow	optional	optional	optional
NLE attachable (NAS)	–	–	–
<b>Formats/Codecs</b>			
SD	✓	✓	✓
HD 720p/1080i	✓	✓	✓
1080p 50/60	–	–	✓
Avid DNxHD	✓	✓	✓
Sony XDCAM	✓	✓	✓
Apple ProRes	✓	✓	✓
DVCPRO, MPEG-2	✓	✓	✓
AVC-Intra 50/100/200	✓	✓	✓
2K	–	–	one channel <sup>1</sup>
4:4:4	–	–	one channel <sup>1</sup>
Uncompressed	–	–	one channel <sup>1</sup>
<b>Software Features</b>			
Proxy file generation	–	✓	✓
Batchlist recording	–	✓	✓
Batchlist transcoding	–	–	✓
File ingest	–	–	✓

1) One channel on two-channel system and up to two channels on four-channel system.

Apart from the differences mentioned in the table above, the VENICE 2U variants are in most respects identical. Wherever required the specialities of these variants will be detailed in this hardware guide.



Further information about the VENICE 2U variants can be found in section “Overview of the Rear” on page 2-13 and section “Digital Video I/Os” on page 2-14.



The following table shows the hardware specifications of VENICE 2U as they are available for each video channel pair (ch. 1/2 or ch. 3/4). General annotations as well as the information concerning only either one or the other variant are detailed in footnotes.

**Table 2-1: VENICE 2U specifications per video channel pair**

Video	Input	Output
HDMI 1.4 a (optional)		1 HDMI <sup>1</sup>
HDMI 1.3 (optional)		1 HDMI <sup>1</sup>
SDI (serial digital interface) 4:2:2 8/10 bit (single link)	2 streams via 2 BNC <sup>2</sup>	2 streams via 2 BNC
SDI (serial digital interface) 4:4:4 8/10/12 bit (dual link) <sup>3, 4</sup>	1 stream via 2 BNC <sup>2</sup>	1 stream via 2 BNC <sup>2</sup>
SDI (serial digital interface) 4:4:4 8/10/12 bit (3 Gbit/s) <sup>3, 4</sup>	2 streams via 2 BNC <sup>2</sup>	2 streams via 2 BNC <sup>2</sup>
Reference	Input	Output
Analog reference genlock	1 BNC <sup>2</sup>	
Audio	Input	Output
Embedded audio, 16 digital channels (mono)	1 BNC per stream (via Video In) <sup>2</sup>	1 BNC per stream (via Video Out)
AES/EBU, 8 digital channels (mono)	1 DB-25 per channel (XLR via breakout cable) <sup>2</sup>	1 DB-25 per channel (XLR via breakout cable)
Timecode	Input	Output
Longitudinal (LTC) <sup>4</sup>	1 Mini XLR female <sup>2</sup>	1 Mini XLR male
Vertical (VITC)	1 BNC per stream (via Video In) <sup>2</sup>	1 BNC per stream (via Video Out)
Data and Control Interfaces	Input	Output
Serial RS-422	2 DB-9 female (pin-out will be switched by the software)	
Data Formats		
Color Modes <sup>3</sup>	YCbCr 4:2:2 YCbCrA 4:2:2:4 RGB 4:4:4 RGBA 4:4:4:4	

Storage Format <sup>3</sup>	Compressed or uncompressed YUV 4:2:2 YUVA 4:2:2:4 RGB 4:4:4 RGBA 4:4:4:4 all in 8/10 bit, user selectable
Internal Processing	Color space conversion Frame repetition Realtime scaler Input raster detection
Audio Formats	48 kHz, 16/24/32 bit

- 1) Optionally available for all VENICE 2U variants.
- 2) Only available for VENICE 2U with ingest option
- 3) Only VENICE 2U with ingest and transform option operates in 4:4:4 and 4:4:4:4 mode.
- 4) Available for the first video channel of a video channel pair.



*VENICE 2U (hardware variant with default playout capability as well as the variant with ingest option):*

The in- and output of 2K, 4:4:4 and uncompressed video material is not possible when using VENICE 2U with only the default playout capability and only ingest option.

*VENICE 2U (hardware variant with ingest and transform option):*

The in- and output of 2K, 4:4:4 and uncompressed video material is restricted to one video channel if using only the system's local storage. Then the other video channels may not be used. This applies to the VENICE 2U two-channel as well as to the four-channel variant.

Furthermore, the in- and output of video material in AVC-Intra is possible to on two video channels (four video channels with the VENICE 2U four-channel variant) at the same time.

*General note:*

Please note that the above stated cannot be guaranteed under all circumstances. Beside the video format, bit depth, color space, or file format used they also depend, for example, on the number of processes/user interfaces running on the system or whether external accesses to the storage are taking place. The information above should be taken as approximations only that may work under ideal circumstances.



## 2.2 Overview of the Front

### 2.2.1 The Front of the System

This section provides an overview of the front of the system:

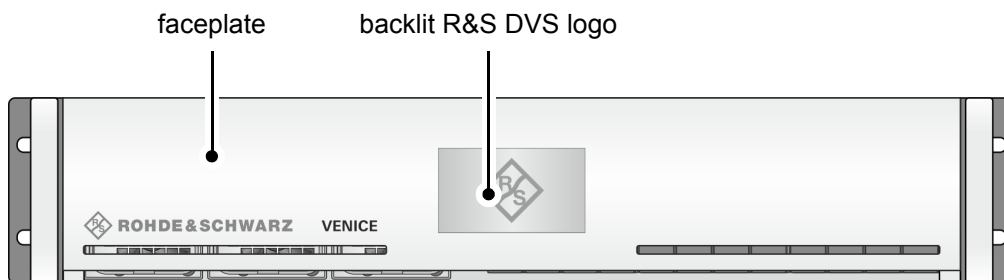

Figure 2-1: Overview of the front

The faceplate covers the fan area, the operation items in the middle of the device and the hard disk array.

It is built with an integrated backlit R&S DVS logo which indicates the state of the system, i.e. its power-on status: If the R&S DVS logo is illuminated, the power is turned on; if not, the power is turned off.

The bottom side of the faceplate is hinge-fastened, while its top side is fixed with magnets. If you need access, for example to the operation items, you just have to fold down the faceplate:

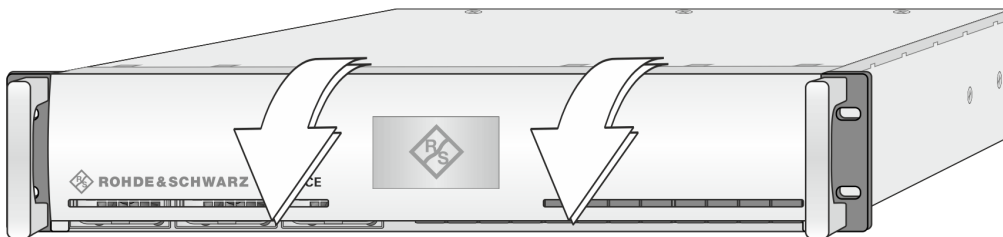

Figure 2-2: Opening the faceplate

Then you can access the operation items (see section “Operation Items” on page 2-8), the fans of the fan area (see section “Fan Area” on page 2-11) and the hard disks of the hard disk array (see section “Hard Disk Array” on page 2-9).



The faceplate can be removed for transport reasons (see section “Removal of the Faceplate” on page 5-14).

Once the faceplate is folded down (see section “The Front of the System” on page 2-6), you have access to the uncovered front of the system:

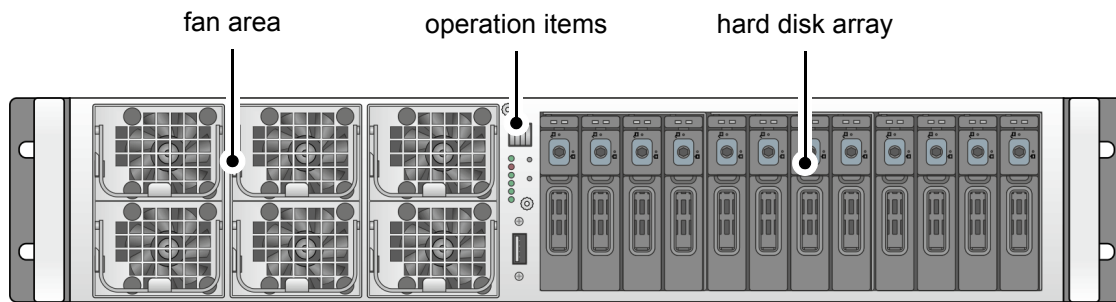

Figure 2-3: Uncovered front of the R&S DVS system

fan area	To cool the electronic parts (e.g. the motherboard) installed in VENICE 2U, the system is equipped with six fans that can be exchanged in case of a failure easily. Further information about the fan area can be found in section “Fan Area” on page 2-11.
operation items	With the operation items the system can be controlled (e.g. turned on or off). Additionally, they offer some LEDs that allow you to assess the state of the R&S DVS system and the network connection, as well as an USB 3.0 connector for an easy connectivity of additional devices such as memory sticks. Further information about the operation items can be found in section “Operation Items” on page 2-8.
hard disk array	The hard disk array contains the main storage which can be used to store video and audio material as well as the system/metadata hard disks. All disks can be replaced easily in case of failure. The disk array is described in more detail in section “Hard Disk Array” on page 2-9.



## 2.2.2 Operation Items

With the operation items at the system's front the hardware of VENICE 2U can be controlled (e.g. turned on or off). There you can also find LEDs that allow you to assess the state of the R&S DVS system and the network connection, as well as an USB 3.0 connector.

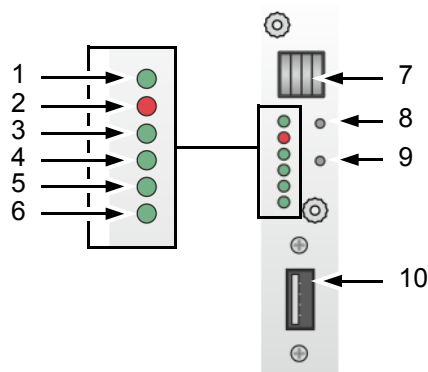



Figure 2-4: Operation items overview

No.	Item	Explanation
1	power LED	This LED lights up when the system has been turned on and is now operating.
2	alarm LED	<p>This LED lights up when a hardware malfunction has occurred.</p> <p> It is recommended to configure the VENICE 2U system for an automatic e-mail notification accounting for all possible hardware malfunctions such as power supply or fan failure. In some cases no alarm buzzer will be sounded, so you have to check the state of the alarm LED at regular intervals otherwise.</p> <p>Further information about what to do in case of a hardware failure can be found in section "Troubleshooting" on page A-2.</p>
3	LAN 0 LED	This LED lights up when the network connector LAN 0 (see section "ATX Connector Panel" on page 2-20) is connected to a network.
4	LAN 1 LED	Same as 'LAN 0 LED' but for LAN 1
5	LAN 2 LED	Same as 'LAN 0 LED' but for LAN 2

No.	Item	Explanation
6	LAN 3 LED	Same as 'LAN 0 LED' but for LAN 3
7	contact surface	When the faceplate is closed, this contact surface is connected to a matching interface at the inside of the faceplate. It provides power to light up the R&S DVS logo.
8	power	The power switch turns the system on or off. The respective state of the system will be indicated by the R&S DVS logo in the middle of the faceplate (see section "The Front of the System" on page 2-6) as well as the power LED.
6	reset	Resets your system and initiates a warm reboot. Use a thin, pointed object to press this button.  <div style="border: 1px solid black; padding: 2px; display: inline-block;"><b>NOTICE</b></div> <b>Resetting the system</b> When resetting the system without having saved data, data may get lost.  <b>Save your data before resetting the system.</b>
10	USB 3.0 port	The USB 3.0 connector (universal serial bus) offers you the possibility to transfer media, e.g. to a R&S DVS mobile storage quickly.

### 2.2.3 Hard Disk Array

The hard disks of the hard disk array are used to store your video and audio material. Among them you can find the main storage of the R&S DVS system as well as the system/metadata hard disks. To prevent data loss in case a hard disk fails, it is normally RAID protected. Furthermore, the system/metadata hard disks are protected with a battery backup unit to prevent data loss, for example, in case of a power failure.



Further information about RAID and the location of the main storage and system/metadata hard disks can be found in section "Introduction to RAID" on page 5-2. The battery backup unit is described in section "Battery Backup Unit" on page 2-24.

Once the faceplate is folded down (see section "The Front of the System" on page 2-6), you have access to the hard disk array:

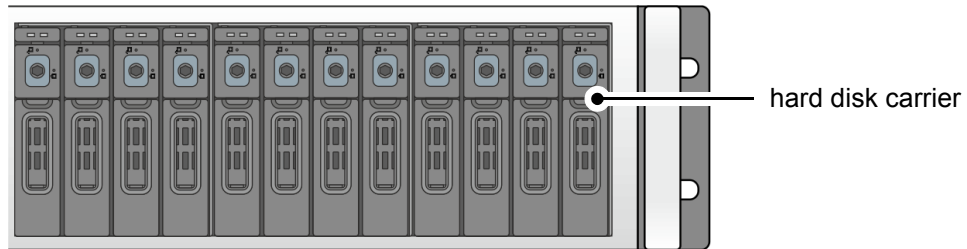

Figure 2-5: Hard disk array

Each hard disk of the array is connected to the system with the help of a disk carrier which makes the removal of a hard disk from the system easy, for example, in the event of a failure.

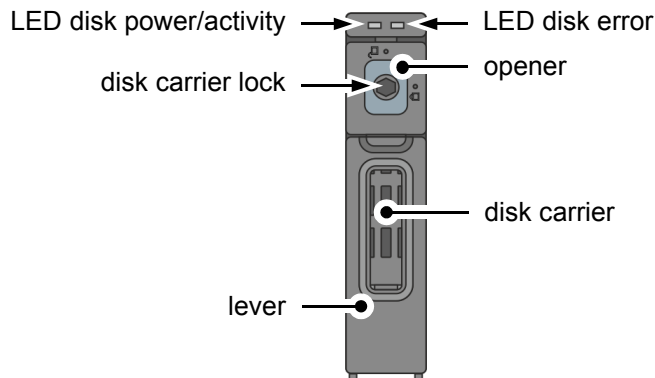

Figure 2-6: Hard disk carrier overview



Further information about how to remove and exchange a hard disk can be found in section “Hard Disk Maintenance” on page 5-2.

LED disk power/ activity	This LED lights up in blue and indicates whether the disk of the disk carrier receives power as well as the status of the hard disk: steady light: hard disk receives power blinking light: there is activity on this particular hard disk
LED disk error	This LED lights up in red when a hard disk or disk carrier related error has occurred.
opener	Unlatches the lever and with it the disk carrier.
disk carrier	The disk carrier holds one hard disk of the array. The hard disk is mounted to the disk carrier with several screws normally located at the sides of the carrier.



lever	Once the lever is unlatched with the opener, it can be used to pull the disk carrier and its hard disk out of the system.
disk carrier lock	The disk carrier can be locked (unlocked) with a hex driver. Use a hex key to turn the lock a quarter turn right (left) until you feel a slight resistance. Then, the disk carrier should be locked (unlocked). The open padlock symbol at the top (🔓) and the closed padlock symbol at the right side (🔒) of the opener, also indicate the direction you have to turn the hex key in.

## 2.2.4 Fan Area

To cool the electronic parts (e.g. the motherboard) installed in VENICE 2U, the system is equipped with six fans that can be exchanged in case of a failure easily. Once the faceplate is folded down, you have access to the fan area.



How to fold down the faceplate is described in section “The Front of the System” on page 2-6.

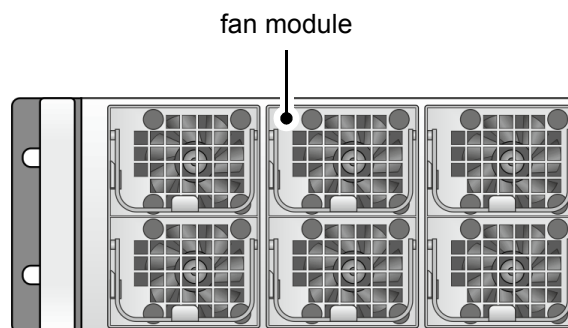

Figure 2-7: Overview of the fan area

On the left side of the area, the two fans lying upon another cool the PCI cards (e.g. graphics card) via an inner air duct. The remaining four fans cool the other hardware items like e.g. the motherboard.

Each fan module of the fan area is separately connected to the system. This makes the removal of a fan module from the system easy, for example, in the event of a failure.



Further information about how to remove and exchange a fan can be found in section “Fan Maintenance” on page 5-8.

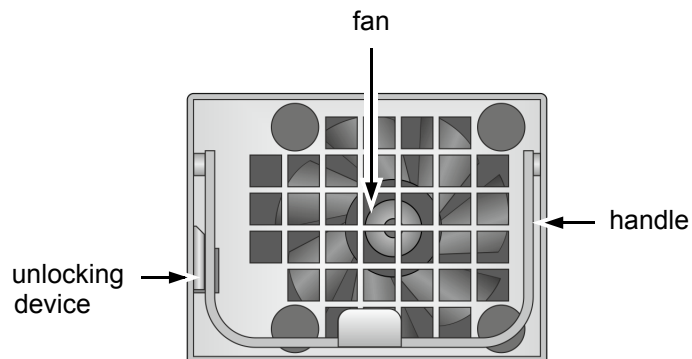



Figure 2-8: Overview of a fan module

Each fan module consists of the unlocking device, the fan and the handle. The handle is used to pull out the fan module in case of a failure. After pressing the unlocking device, the fan module can be pulled out of the VENICE 2U system.

## 2.3 Overview of the Rear

This section describes the rear of the system. After a general overview of the rear of all VENICE 2U hardware variants, some explanatory details about the digital video in- and outputs are given. Next, the main connector panel will be described, followed by detailed descriptions of the power supply, the ATX connector panel and the slot panel connectors.

 The full complement of four video channels and/or HDMI outputs are optionally available. In its standard variant VENICE 2U will be delivered with two video channels and empty connector panels are covered by blind panels.

### 2.3.1 The Rear of the System

This section provides an overview of the rear of the system:

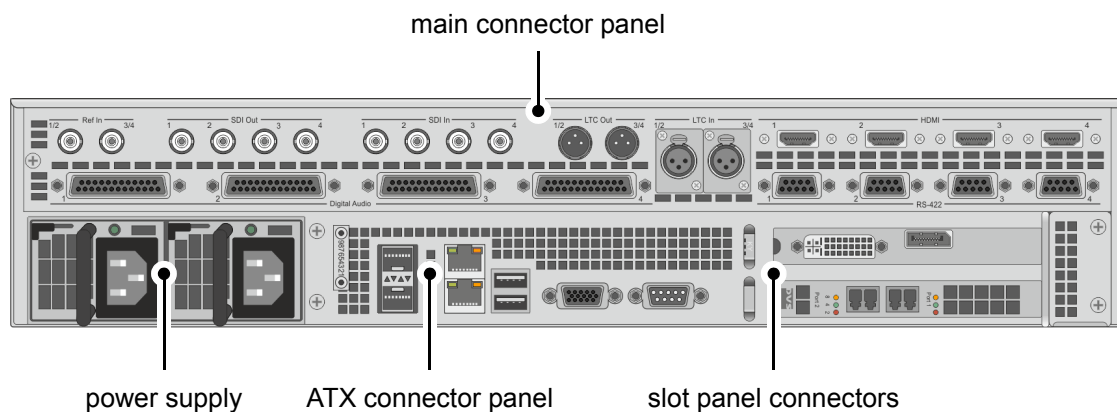

Figure 2-9: Overview of the rear of the VENICE 2U with full featureset

**main connector panel** The main connector panel provides most of the standard in- and outputs of VENICE 2U to give you the full functionality of the system. It holds, for example, the connectors for remote control and video I/Os. It is in more detail described in section “Main Connector Panel” on page 2-16.

**power supply** The redundant power supply provides the system with power. It consists of two independent power supply units: Even if one fails the other will still supply enough power to keep the system operational. Further information about the power supply can be found in section “Power Supply” on page 2-19.



- ATX connector panel On this panel you can find the standard connectors of the computer system. Further information about them can be found in section “ATX Connector Panel” on page 2-20.
- slot panel connectors The slot panel connectors of the R&S DVS system provide, for example, connectors that can be used to connect external storages, and the graphics card panel. If applicable, other panels may be installed for internal reasons or on customer request. More details about the slot panel connectors can be found in section “Slot Panel Connectors” on page 2-22.

### 2.3.2 Digital Video I/Os

This section contains some information about the digital video in- and outputs of VENICE 2U.



The full complement of four video channels is optionally available. In its standard variant VENICE 2U will be delivered with two video channels. The HDMI connectors are optionally available. In- and output of 2K, 4:4:4 and uncompressed video material is only possible with a VENICE 2U system including the ingest and transform option.

The following information may not be valid for all VENICE 2U hardware variants. Further information about VENICE 2U and available options can be found in section “R&S®VENICE 2U Models” on page 2-2.

R&S DVS usually names the input/output connectors/ports of the digital video signals alphabetically: the main video stream is then available, for instance, on port A and the secondary video stream on port B. Individual video channels on the other hand are labeled with numbers.

#### SDI in- and output

For YUV you normally require one link (connectors named ‘A’, single link). For YUVA you will need two links (‘A’ for YUV and ‘B’ for the key signal). With RGB you will always need two links (‘A’ and ‘B’, dual link).

Because VENICE 2U provides up to four independent video channels (different video rasters and color modes), up to four SDI input ports and four SDI output ports are available. With this YUV can be transmitted by all channels independently by default. By changing the speed of the ports to 3-Gbit/s SDI, independent dual-link connections can be realized. They provide all the features of a standard dual-link connection, but require only one connector instead of two.

Video channel 1 and, if available, video channel 3 can also be switched to a standard dual-link connection. Then, the second video channels of

the video channel pairs 1/2 and 3/4 (i.e. channels 2 and 4) will not be available and their SDI ports have to be used for the secondary video signal (link B).

The following tables show the signal distribution over the I/O ports for the different color modes when either SDTV or a 1.5-Gbit/s connection are configured for the channels, or the channels are set to 3 Gbit/s:

**Table 2-2: SDI signal distribution, SDTV and 1.5 Gbit/s SDI**

Color Mode	SDI In		SDI Out	
	Ch. 1/Ch. 3	Ch. 2/Ch. 4	Ch. 1/Ch. 3	Ch. 2/Ch. 4
YC <sub>b</sub> C <sub>r</sub> 4:2:2	Y, C <sub>b</sub> , C <sub>r</sub>	Y, C <sub>b</sub> , C <sub>r</sub>	Y, C <sub>b</sub> , C <sub>r</sub>	Y, C <sub>b</sub> , C <sub>r</sub>
YC <sub>b</sub> C <sub>r</sub> A 4:2:2:4	Y, C <sub>b</sub> , C <sub>r</sub>	A (key)	Y, C <sub>b</sub> , C <sub>r</sub>	A (key)
YC <sub>b</sub> C <sub>r</sub> 4:4:4	Y, ½ C <sub>b</sub> , ½ C <sub>r</sub>	½ C <sub>b</sub> , ½ C <sub>r</sub>	Y, ½ C <sub>b</sub> , ½ C <sub>r</sub>	½ C <sub>b</sub> , ½ C <sub>r</sub>
YC <sub>b</sub> C <sub>r</sub> A 4:4:4:4	Y, ½ C <sub>b</sub> , ½ C <sub>r</sub>	½ C <sub>b</sub> , ½ C <sub>r</sub> , A (key)	Y, ½ C <sub>b</sub> , ½ C <sub>r</sub>	½ C <sub>b</sub> , ½ C <sub>r</sub> , A (key)
RGB 4:4:4	G, ½ R, ½ B	½ R, ½ B	G, ½ R, ½ B	½ R, ½ B
RGBA 4:4:4:4	G, ½ R, ½ B	½ R, ½ B, A (key)	G, ½ R, ½ B	½ R, ½ B, A (key)

**Table 2-3: SDI signal distribution, 3-Gbit/s SDI**

Color Mode	SDI In		SDI Out	
	Ch. 1/Ch. 3	Ch. 2/Ch. 4	Ch. 1/Ch. 3	Ch. 2/Ch. 4
YC <sub>b</sub> C <sub>r</sub> A 4:2:2:4 <sup>1</sup>	Y, C <sub>b</sub> , C <sub>r</sub> , A (key)	Y, C <sub>b</sub> , C <sub>r</sub> , A (key)	Y, C <sub>b</sub> , C <sub>r</sub> , A (key)	Y, C <sub>b</sub> , C <sub>r</sub> , A (key)
YC <sub>b</sub> C <sub>r</sub> 4:4:4 <sup>1</sup>	Y, C <sub>b</sub> , C <sub>r</sub>	Y, C <sub>b</sub> , C <sub>r</sub>	Y, C <sub>b</sub> , C <sub>r</sub>	Y, C <sub>b</sub> , C <sub>r</sub>
YC <sub>b</sub> C <sub>r</sub> A 4:4:4:4 <sup>1</sup>	Y, C <sub>b</sub> , C <sub>r</sub> , A (key)	Y, C <sub>b</sub> , C <sub>r</sub> , A (key)	Y, C <sub>b</sub> , C <sub>r</sub> , A (key)	Y, C <sub>b</sub> , C <sub>r</sub> , A (key)
RGB 4:4:4 <sup>1</sup>	R, G, B	R, G, B	R, G, B	R, G, B
RGBA 4:4:4:4 <sup>1</sup>	R, G, B, A (key)	R, G, B, A (key)	R, G, B, A (key)	R, G, B, A (key)

1) Not available for SD video rasters. For this you have to use SDTV and 1.5 Gbit/s SDI.

## HDMI output

*VENICE 2U*: You can select the HDMI port(s) (optional) of VENICE 2U by setting the output priority in the software to 'DVI' and then selecting the raster.

The first and, if available, the third HDMI port of VENICE 2U (i.e. video channels 1 and 3, ports labelled 'HDMI 1' and 'HDMI 3') are HDMI 1.4 a, providing all outputs up to 2K. When using a 2K raster on these ports, the second video channels of the video channel pairs 1/2 and 3/4 (i.e. video channels 2 and 4, ports labelled 'HDMI 2' and 'HDMI 4') will not be available. This description refers to the four-channel variant of VENICE 2U.



### 2.3.3 Main Connector Panel

The main connector panel provides the standard in- and outputs of VENICE 2U to give you the full functionality of the system. It holds, for example, the digital video in- and outputs (serial digital interface) and the connectors for remote control.



Pin-outs of most connectors can be found in section “Signal In- and Outputs” on page A-7.

The following information may not be valid for all VENICE 2U hardware variants. Wherever required, not provided or optionally available connectors are indicated for the specific system. No indication in the table below means that the connector is provided as standard for all VENICE 2U variants.

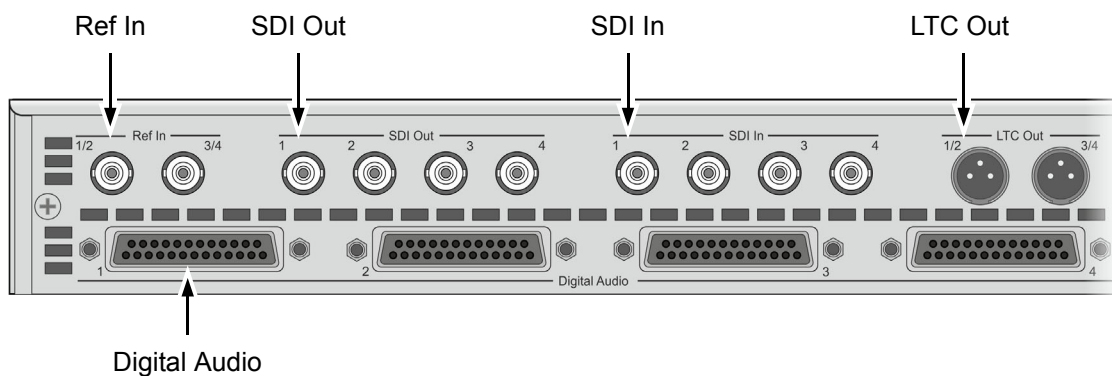

Figure 2-10: Main connector panel on rear (left half)

Item	Description
Ref In 1/2	BNC connector for the reference input for channels 1 and 2 For further information about the sync settings, see chapter ‘Level Administrator’ in the “VENICE Client Software” user guide.
Ref In 3/4	Same as ‘Ref In 1/2’ but for video channels 3 and 4
SDI Out 1	BNC connector for an output of digital video signals (serial digital interface); usually used for an output of single-link (YUV) or 3-Gbit/s (YUVA or RGB[A]) video signals for video channel 1; can also be used for dual-link modes of video channel 1 (first video stream, port A)

Item	Description
SDI Out 2	BNC connector for an output of digital video signals (serial digital interface); usually used for an output of single-link (YUV) or 3-Gbit/s (YUVA or RGB[A]) video signals for video channel 2; can also be used for dual-link modes of video channel 1 (second video stream, port B)
SDI Out 3	Same as 'SDI Out 1' but for video channel 3
SDI Out 4	Same as 'SDI Out 2' but for video channel 4; can also be used for dual-link modes of video channel 3 (second video stream, port B)
SDI In 1	BNC connector for an input of digital video signals (serial digital interface); usually used for an input of single-link (YUV) or 3-Gbit/s (YUVA or RGB[A]) video signals for video channel 1; can also be used for dual-link modes of video channel 1 (first video stream, port A)  (Only for VENICE 2U with ingest option)
SDI In 2	BNC connector for an input of digital video signals (serial digital interface); usually used for an input of single-link (YUV) or 3-Gbit/s (YUVA or RGB[A]) video signals for video channel 2; can also be used for dual-link modes of video channel 1 (second video stream, port B)  (Only for VENICE 2U with ingest option)
SDI In 3	Same as 'SDI In 1' but for video channel 3
SDI In 4	Same as 'SDI In 2' but for the video channel 4; can also be used for dual-link modes of video channel 3 (second video stream, port B)
LTC Out 1/2	Mini XLR connector (male) for an output of longitudinal timecode of video channel 1
LTC Out 3/4	Mini XLR connector (male) for an output of longitudinal timecode of video channel 3
Digital Audio 1	DB-25 connector (female) for a balanced audio signal in- and output of the digital audio channels 1 to 8 (AES/EBU) for video channel 1; XLR connectors are available via a breakout cable
Digital Audio 2	Same as 'Digital Audio 1' but for video channel 2



Item	Description
Digital Audio 3	Same as 'Digital Audio 1' but for video channel 3
Digital Audio 4	Same as 'Digital Audio 1' but for video channel 4

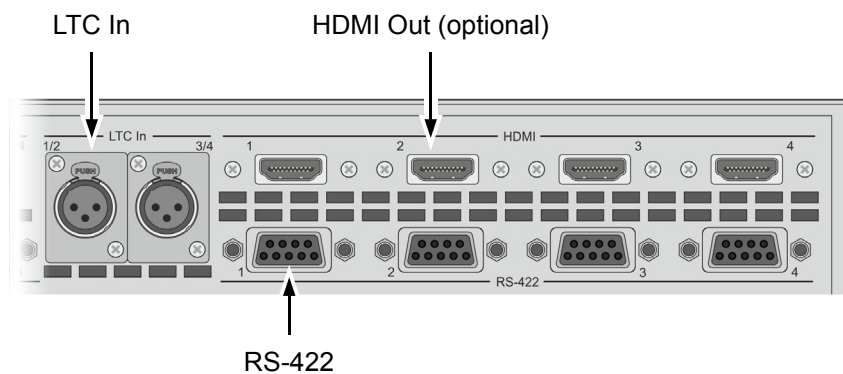

Figure 2-11: Main connector panel on rear (right half)

Item	Description
LTC In 1/2	Mini XLR connector (female) for an input of longitudinal timecode for video channels 1 and 2 (Only for VENICE 2U with ingest option)
LTC In 3/4	Mini XLR connector (female) for an input of longitudinal timecode for video channels 3 and 4 (Only for VENICE 2U with ingest option)
HDMI 1	HDMI 1.4 a connector for an output of digital audio and video signals for video channel 1; at a resolution of 2K this channel uses the resources of the second channel of the video channel pair 1/2, whereby it will not be available at that time (optional)
HDMI 2	HDMI 1.3 connector for an output of digital audio and video signals for video channel 2; this port is not available when HDMI 1 is operating in HDMI 1.4 a mode (optional)
HDMI 3	Same as 'HDMI 1' but for video channel 3
HDMI 4	Same as 'HDMI 2' but for video channel 4



Item	Description
RS-422 1	DB-9 connector (female), serial RS-422 interface for an out- or input of master/slave control signals for video channel 1; its pin-out (master or slave) will be switched by the software automatically
RS-422 2	Same as 'RS-422 1' but for video channel 2
RS-422 3	Same as 'RS-422 1' but for video channel 3
RS-422 4	Same as 'RS-422 1' but for video channel 4

### 2.3.4 Power Supply

The redundant power supply provides the system with power. It consists of several independent power supply units. Even if one fails the other will still offer enough power to keep the system working.

#### NOTICE

#### Second power supply failure

The system can be operated with one power supply unit out of order. However, if another one fails, a continued operation of the system cannot be guaranteed.

**It is recommended to change a failed power supply unit immediately (see section "Power Supply Maintenance" on page 5-15).**



The state of the power supply units can be easily checked either with their LEDs as explained below or with the general alarm LED (see section "Operation Items" on page 2-8).

The following provides an overview of the power supply:

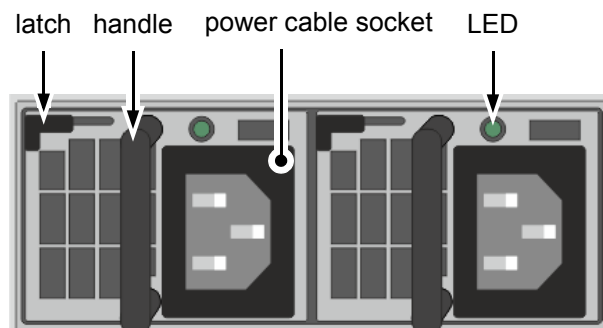

Figure 2-12: Overview of the power supply



latch	The latch of a power supply unit locks it in the power supply. With it the unit can be unlocked and pulled out of the system with the help of the handle.
handle	With the handle of the power supply unit you can pull the unit out of the system once it is unlocked with the latch.
power cable socket	The socket where the power cable has to be plugged in to provide the system with power.
LED	The LED indicates the state of the power supply unit:
green	operating normally
off	standby mode
off (alarm LED within operation items on)	disconnected from power or malfunction

### 2.3.5 ATX Connector Panel

The ATX connector panel on the rear of the R&S DVS system holds the connectors of the computer system. It provides the following connections:

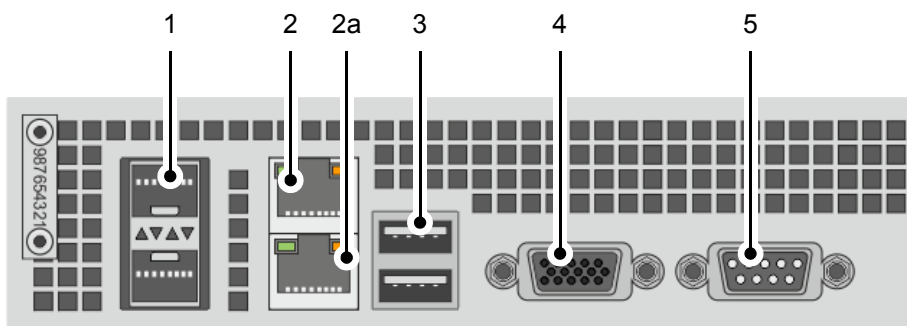



Figure 2-13: ATX connector panel on rear

No.	Item	Explanation
1	LAN ports 1	<p>10-Gbit/s Ethernet (optical SFP+) connection ports to connect the system to a network (LAN and WAN). The upper connector's state (network connector LAN 0) is indicated by the LAN 0 LED and the lower connector's state (network connector LAN 1) by the LAN 1 LED within the operation items (see section "Operation Items" on page 2-8).</p> <div style="display: flex; align-items: center;">  <p>Please observe that you need SFP+ modules to make use of the Ethernet connection ports.</p> </div>
2	LAN ports 2 (eth0)	<p>1-Gbit/s Ethernet (1000 Base-T) connection ports to connect the system to a network. The upper connector's state (network connector LAN 2) is indicated by the LAN 2 LED and the lower connector's state (network connector LAN 3) by the LAN 3 LED within the operation items (see section "Operation Items" on page 2-8).</p>
2a	IPMI (eth1)	<p>Dedicated LAN port for IPMI v2.0 (Intelligent Platform Management Interface) providing SNMP and KVM (Keyboard, Video, Mouse redirection) as well; for further information see section "SNMP – Simple Network Management Protocol" on page 2-25 or the documentation(s).</p>
3	USB 2.0 ports	<p>These USB 2.0 connectors (universal serial bus) offer you the possibility to connect other devices (e.g. mouse and keyboard) to your system.</p>
4	VGA	<p>DB-15 connector (female) to connect a monitor; normally with an extra graphics card installed, this connector will not be operational; however, it can be used in combination with IPMI/KVM for system management; if you want to use this port, please contact R&amp;S DVS directly in case of setup questions.</p>
5	COM port	<p>RS-232 connector for the connection of serial interface devices</p>

## 2.3.6 Slot Panel Connectors

VENICE 2U provides on its slot panel connector area various connections, such as the graphics card panel and an expansion slot for optional Fibre Channel HBA. If applicable, other panels may be present for internal reasons or on customer request.

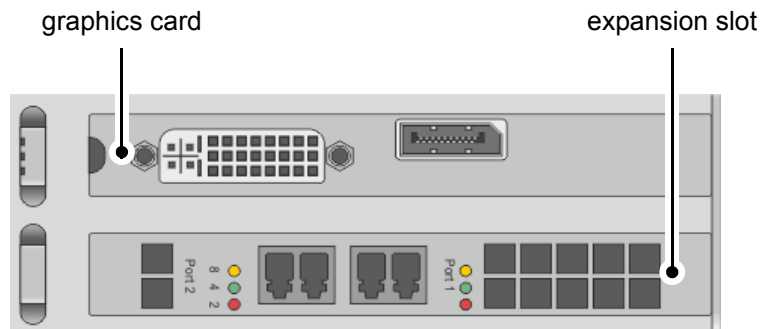

Figure 2-14: Slot panels on rear



The layout of the slot panel area on your system may differ from the figure above: The position of the individual slot panels may vary and other panels may be installed for internal reasons or on customer request.

### Graphics Card

The graphics card panel is the panel where normally a dual-link DVI-I and a DisplayPort are located. The monitor for the VENICE 2U software has to be connected here. For further information about the graphics card, please refer to the original manufacturer's documentation included in the delivery of the R&S DVS system.

### Expansion Slot

The expansion slot for an optional Fibre Channel HBA (host bus adapter) is a PCIe interface with a bandwidth of 8 lanes and a data transmission rate of up to 8 Gigabits per second that can be used to connect e.g. external storages. An external storage connected to this port can even be configured to provide RAID protection.

The currently transferred data rate is indicated by the LEDs on the left and right side of the ports. The transmission rate can be detailed as follows:

yellow LED	The interface operates with the maximum available transmission rate of 8 Gbit/s.
green LED	The interface operates with a transmission rate of 4 Gbit/s.

red LED	The interface operates with a transmission rate of 2 Gbit/s.
All LEDs off	No external device has been connected to the port.

**NOTICE**

**Data transfers on this port**

Data transfers on this port may interfere with the realtime capability of the R&S DVS system.

**It is recommended to use this port only at times when no realtime performance is required.**



If the data rate settings in the Spycer application have been configured appropriately (see "Spycer" user guide) the transmission rate should be limited and no realtime interference should take place. For this reason, it is recommended to use Spycer for data transfers.



## 2.4 Battery Backup Unit

To prevent data loss especially for the metadata, the system/metadata hard disks (see section “Introduction to RAID” on page 5-2) are protected by a battery backup unit (BBU). If the system’s operation gets interrupted, for example, in case of a power failure, it will provide power to the cache of the connected RAID controller, so that buffered data will not get lost. Once the operation of the system is restored, the cached data will be written to the hard disks.

The battery backup unit is located inside the casing of the R&S DVS system, above the power supply, protected by a metal casing:

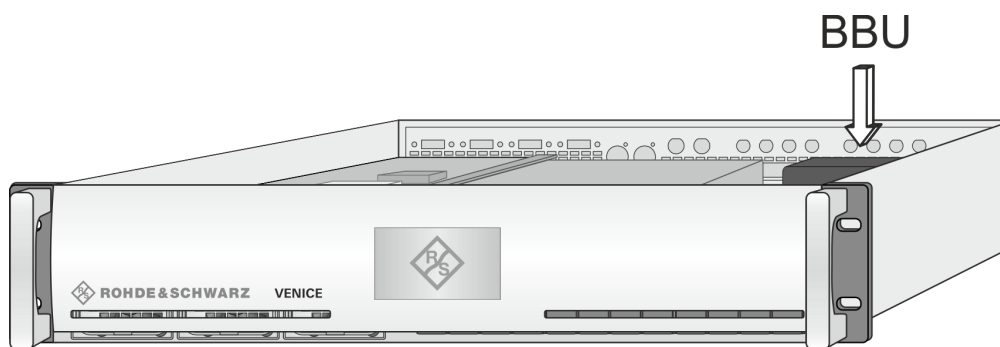

Figure 2-15: Location of battery backup unit inside the system



The position of the battery backup unit may vary depending on the system.

The battery backup unit is a rechargeable battery that will be charged automatically when the system is turned on.

## 2.5 SNMP – Simple Network Management Protocol

The Simple Network Management Protocol (SNMP) is a standard internet protocol for the device management in IP networks. With it, you can e.g. monitor and query the state of several VENICE 2U devices in a network or single parts of the hardware. VENICE 2U provides a *NET-SNMP-EXTEND-MIB* file and an *LSI-AdapterSAS* file that give you the opportunity to query the state of the system or parts of it, using the Simple Network Management Protocol (SNMP).

To query the system, it is recommended to install a standard MIB browser on an external monitoring device where you have to set the IP address of the VENICE 2U server. The system's minimum and maximum limits are predefined by R&S DVS and have to be entered into the respective fields in the MIB browser. You find all necessary information in the *NET-SNMP-EXTEND-MIB* file and the *LSI-AdapterSAS* file that refers to the RAID controller in the path `/usr/local/ipmi` on the VENICE 2U server. By loading the *NET-SNMP-EXTEND-MIB* and the *LSI-AdapterSAS* files in the MIB browser, it is then possible to query the state of the system.

The query of a special hardware component may be started by entering an OID (object identifier) path in the MIB browser. The OID path consists of two parts: The first one is the standard VENICE 2U path to the objects in the MIB Tree and predefined as numbers as e.g.

`.1.3.6.1.4.1.8072.1.3.2.3.1.4.`

The second part consists of the number of characters (the first number) as well as the decimal ASCII code of the characters (e.g. 'FAN1A0'):

- (1) *FAN1A0* = 6.70.65.78.49.65.48
- (2) *FAN2B1* = 6.70.65.78.50.66.49

The decimal ASCII descriptions of e.g. FAN1A0 and FAN2B1 are detailed in the following:

**Table 2-4: Decimal ASCII descriptions of FAN1A0 and FAN2B1**

(1) <i>FAN1A0</i> =	6.	70.	65.	78.	49.	65.	48.	
Number of characters	↑	F	A	N	1	A	0	
(2) <i>FAN2B1</i> =								
Number of characters	↑	F	A	N	2	B	1	



The complete path to query the state of e.g. FAN1A0 would look as follows in this case:

```
.1.3.6.1.4.1.8072.1.3.2.3.1.4.6.70.65.78.49.65.48
```

The results of the query will be displayed as a listing of the hardware component's path number (second part of OID path), the system's minimum and maximum limits for this hardware component and the current state of it (e.g. the number of revolutions per minute of the fans). The complete ASCII encoding of English capital letters is shown in the following table:

<b>A</b>	<b>B</b>	<b>C</b>	<b>D</b>	<b>E</b>	<b>F</b>	<b>G</b>	<b>H</b>	<b>I</b>	<b>J</b>	<b>K</b>	<b>L</b>	<b>M</b>
△	△	△	△	△	△	△	△	△	△	△	△	△
<b>65</b>	<b>66</b>	<b>67</b>	<b>68</b>	<b>69</b>	<b>70</b>	<b>71</b>	<b>72</b>	<b>73</b>	<b>74</b>	<b>75</b>	<b>76</b>	<b>77</b>
<b>N</b>	<b>O</b>	<b>P</b>	<b>Q</b>	<b>R</b>	<b>S</b>	<b>T</b>	<b>U</b>	<b>V</b>	<b>W</b>	<b>X</b>	<b>Y</b>	<b>Z</b>
△	△	△	△	△	△	△	△	△	△	△	△	△
<b>78</b>	<b>79</b>	<b>80</b>	<b>81</b>	<b>82</b>	<b>83</b>	<b>84</b>	<b>85</b>	<b>86</b>	<b>87</b>	<b>88</b>	<b>89</b>	<b>90</b>

## Setup and Configuration of SNMP Monitoring

To set up and configure SNMP for the VENICE 2U system perform the following:

1. Open a command line interface and install all required files by entering the command:  

```
l# ./install_snmp.sh
```
2. Copy the *NET-SNMP-EXTEND-MIB.txt* and *LSI-Adapter-SAS.mib* (monitoring of the LSI adapter) files on your monitoring device and load the MIBs in your MIB browser. The path to the file is  

```
/usr/local/ipmi/NET-SNMP-EXTEND-MIB.txt
```
3. In the left container of your MIB browser you can follow the path to start the query. Navigate to  
**MIB tree >> Private >> enterprises >> netSmp >> netSmpObjects >> nsExtensions >> nsExtendObjects >> nsExtendOutput2Table.**



It is recommended to use the right-click on **nsExtendOutput2Table** and select **TableView** for an optimized display.



 To query the states of the VENICE 2U hardware, you can either use an MIB browser or an SNMP monitoring software. When using a monitoring software, you will have to enter all OIDs once to be able to monitor the hardware's state continuously. You will be able to define critical values and configure an e-mail notification as well.

**Table 2-5: Explanation of the OIDs and position of the objects**

<b>Fans:</b>		
	Min. value of rounds per minute Unit: RPM	
Name of object (decimal ASCII description)	Current values for the FAN1A/FAN1B	Position
Name of object (decimal ASCII description)	Current values for the FAN2A/FAN2B	Position
	...	...
<b>CPUs:</b>		
Name of object (decimal ASCII description)	Max. value of the temperature Unit: C (Celsius)	
Name of object (decimal ASCII description)	Current temperature of the CPU0	Position
Name of object (decimal ASCII description)	Current temperature of the CPU1	Position
	...	...
<b>InletM:</b>		
Name of object (decimal ASCII description)	Max. value of the temperature Unit: C (Celsius)	
Name of object (decimal ASCII description)	Current inlet temperature	
<b>CPU-Voltageregulators (VRD):</b>		
	Max. value of the temperature Unit: C (Celsius)	
Name of object (decimal ASCII description)	Current temperature of the VRD0	Position
Name of object (decimal ASCII description)	Current temperature of the VRD1	Position
	...	...



**Table 2-5: Explanation of the OIDs and position of the objects**

<b>RAM:</b>		
	Max. value of the temperature Unit: C (Celsius)	
Name of object (decimal ASCII description)	Current temperature of the RAM_00	Position
Name of object (decimal ASCII description)	Current temperature of the RAM_01 ...	Position ...
<b>AddinCard:</b>		
	Max. value of the temperature Unit: C (Celsius)	
Name of object (decimal ASCII description)	Current temperature of the AddinCard	Description: Inlet temperature
<b>Plattform Controller Hub (PCH):</b>		
	Max. value of the temperature Unit: C (Celsius)	
Name of object (decimal ASCII description)	Current temperature of the PCH	Position
<b>+5V Voltage:</b>		
	Min. and max. values of the +5 V voltage Unit: V (Volt)	
Name of object (decimal ASCII description)	Current value for the +5 V voltage	
<b>3V Stand-by-Voltage (3VSB):</b>		
	Min. and max. values of the 3V stand-by-voltage Unit: V (Volt)	
Name of object (decimal ASCII description)	Current value for the 3VSB voltage	
<b>CMOS-Battery Voltage (VBAT):</b>		
	Min. and max. values of the CMOS-battery voltage Unit: V (Volt)	
Name of object (decimal ASCII description)	Current value for the VBAT voltage	Position
<b>3VMAIN Voltage:</b>		
	Min. and max. values of the 3VMAIN voltage Unit: V (Volt)	
Name of object (decimal ASCII description)	Current value for the 3VMAIN voltage	



**Table 2-5: Explanation of the OIDs and position of the objects**

<b>PSUs:</b>		
	On/off state for the PSU Unit: Presence detected or Failure detected	
Name of object (decimal ASCII description)	Current state for the PSU1	Position
Name of object (decimal ASCII description)	Current state for the PSU2	Position

## Overview

▶SNMP – Simple Network Management Protocol

---





# Installation

## Contents

System Setup .....	3-2
Note about the Network Installation .....	3-3



## 3.1 System Setup

To install the hardware of VENICE 2U perform the following:

1. Unpack the R&S DVS system and its accessories.



Check your delivery and compare it with the delivery note included in the package on an extra sheet of paper. In case of missing items, please contact your local vendor or R&S DVS immediately.

### NOTICE

#### Incorrect packaging

The warranty will be void if you do not transport the R&S DVS device in the original packing.

**You have to keep the original packing and use it in case of a return transportation.**

2. Place the R&S DVS system on a firm, flat surface within reach of a power outlet or mount it in a rack. For good air circulation and cooling make sure the ventilation holes are not covered.
3. Connect at least the following computer peripherals:
  - Mouse,
  - keyboard and
  - a monitor that is operable at a resolution of at least 1280 × 1024 pixels (default manufacturing setting).
4. Connect any other peripheral computer and video equipment. For an overview of the panels and connectors at the system's rear see section "Overview of the Rear" on page 2-13.
5. Connect the power cable(s) to the system.

The VENICE 2U hardware is now properly installed and you can switch on the system as described in section "Starting the System" on page 4-2.



After installing the hardware the R&S DVS system has to be set up first before it can be used. How to perform the initial setup is described in detail in the software documentation delivered with the system.

## 3.2 Note about the Network Installation

Because of the amount of possible workflows that customer's may use the VENICE 2U for as well as network connections (see section "Slot Panel Connectors" on page 2-16), this document does not describe how to connect the R&S DVS system to a network or central storage. On the R&S DVS web page ([www.dvs.de](http://www.dvs.de)) you can find some diagrams showing how the VENICE 2U may fit in a workflow/network.

To connect the R&S DVS system to a network/central storage, you should have experience as a network administrator and know how to set up the required network connections on the installation site in hardware as well as software. In case you experience difficulties during the installation, R&S DVS offers you special assistance that will be tailored to your personal needs and which can range from remote diagnosis to on-site services. Please contact the R&S DVS service department for further information about this.



Further information about possibilities to configure the network settings can be found in the "R&S®VENICE Software" user guide and the "R&S®Spycer" user guide.

## Installation

► Note about the Network Installation

---







# Operation

## Contents

Starting the System .....	4-2
Shutting Down the System .....	4-3



This chapter describes how to operate the VENICE 2U hardware. It is explained how to start the system and how to shut it down. For both procedures you have to use the power switch within the operation items at the front of the system.

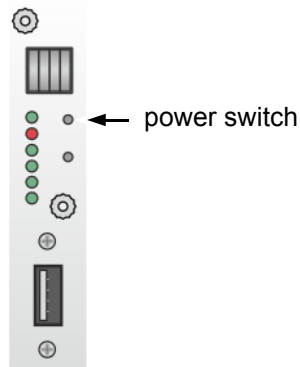

Figure 4-1: The power switch



All other items necessary for a correct operation of the VENICE 2U hardware, such as the LEDs of the hard disk array or the reset button, are described in section “Operation Items” on page 2-8.

## 4.1 Starting the System

After a proper installation of the system (see chapter “Installation” on page 3-1) you may start the R&S DVS system at any time.

To start the system perform the following:

- Press the power switch briefly to turn on the system.

The system will be started and after closing the faceplate the R&S DVS logo in the middle of the faceplate lights up.

As with any standard computer after initial booting, the system begins to load the installed operating system. When the operating system has finished its loading, you can begin to work with the R&S DVS system right away.

## 4.2 Shutting Down the System

There are several possibilities to shut down the R&S DVS system. All depend on whether the operating system is already loaded, frozen or not completely loaded. Please act accordingly.

To shut down the system perform the following according to the state of the system's operating system:

 After a shut-down wait at least ten seconds before starting the system again. This time is needed to safely erase all memory banks of the system.

### With the operating system fully loaded

If the operating system is up and running, there are two ways to shut down your system:

- Turn the system off by shutting down the operating system the usual way.

The operating system will then save your personal settings and once it has ended, the system will turn off.

 Alternatively, you can initiate a fast shut down by pressing the power switch briefly.

#### **NOTICE**

#### **Fast shut down**

The fast shut down may not save all your system data and personal settings before the system turns off.

**Save all data and settings before shutting down the system.**

Some settings will be saved and afterwards the system turns off.

### With the operating system frozen or not completely loaded

If the operating system is not responding anymore or not completely loaded, perform the following:

 This procedure can cause corrupted system data. However, the system should be sufficiently protected against this by the journaling file system and the battery backup unit (see section "Battery Backup Unit" on page 2-19).

- Shut down the system by pressing the power switch until the system turns off.

The system will then shut down immediately.

## Operation

▶ Shutting Down the System

---





# Maintenance

## Contents

Hard Disk Maintenance .....	5-2
Introduction to RAID .....	5-2
Identifying a Broken Hard Disk .....	5-3
Replacing a Hard Disk .....	5-4
Fan Maintenance .....	5-8
Power Supply Maintenance .....	5-10
Opening and Closing the Casing .....	5-12
Opening the Casing .....	5-12
Closing the Casing .....	5-13
Removal of the Faceplate .....	5-14
Backup or Recovery of the System Disk .....	5-15
Creating a Backup Image of the System Disk .....	5-15
Restoring the System Disk .....	5-17



## 5.1 Hard Disk Maintenance

This section deals with the possible event of a hard disk failure. First, some introductory information about RAID are provided. After that follow descriptions how to act when a hard disk fails.

### 5.1.1 Introduction to RAID

In a system where huge amounts of data are processed, large storage capacities combined with high data throughputs are mandatory. To provide both at the same time it is common practice in the area of video and digital film to configure several hard disks together into a stripe set or RAID. The IT world has defined several 'levels' of RAID, most of them providing some kind of data protection.

The RAID feature makes the R&S DVS system tolerant of disk failures. Even with a broken disk operations can still be continued and, once the failed disk has been replaced, the missing data can be recovered easily. The data protection is provided by a RAID controller installed inside the system which independently administers the data protection for the sets of hard disks connected to it.

The system/metadata hard disks are protected by a RAID 1 applied to the data, meaning by a mirroring of the data between two disks. If one of the hard disks fails, the missing data can be restored with the mirrored information stored on the other disk.

#### **NOTICE**

#### **Second disk fail**

If the second disk fails in the meantime, the data will be unrecoverable.

**Replace a broken hard disk immediately.**

The main storage of the R&S DVS system comprises up to 10 hard disks that are protected by a RAID 6 applied to the data. With this, the data is striped across these hard disks during write procedures. At the same time the information necessary to rebuild a failed hard disk (parity information) is generated and written across the disks as well. Because RAID 6 writes the parity information twice to different hard disks (dual parity), up to two hard disks can fail and your data will still be recoverable due to the information stored on the other disks. Especially server systems make use of the RAID 6 feature because, particularly with larger disk capacities, the recovery of a single disk can take a long time and the failure of a second disk in the meantime is not unlikely anymore.

#### **NOTICE**

#### **Third disk fail**

If a third disk fails in the meantime, the data will be unrecoverable.

**Replace a broken hard disk immediately.**

The following figure shows a representation of the hard disk array of the R&S DVS system (see also section “Hard Disk Array” on page 2-9). It indicates the location of the disk sets (RAID packs) in the hard disk array:

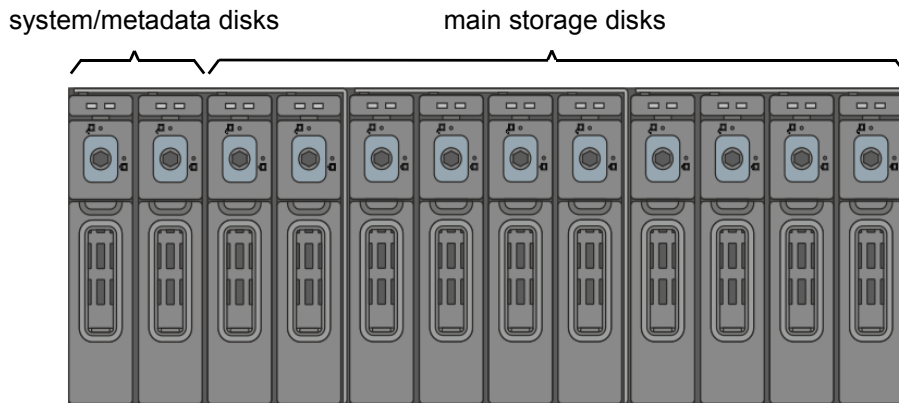

Figure 5-1: Disk sets (RAID packs) of the hard disk array

With the available RAID feature the R&S DVS system can withstand disk failures without losing data or access to data.

## 5.1.2 Identifying a Broken Hard Disk

In case of an alarm or when suspecting a worn hard disk, you have to identify the broken hard disk first in order to replace it.



An alarm can be caused by a number of reasons. Please refer to section “Troubleshooting” on page A-2 first for further details about what to do in case of an alarm.

If a hard disk fails, the alarm will be sounded by a RAID controller. It cannot be switched mute with the mute button of the operation items. It can be turned off either with the RAID software manager or by replacing the broken hard disk.

Data accesses to the hard disk array are still possible because any missing data will be recalculated from the parity information stored on the other hard disk(s). This can limit the overall performance and realtime operations may no longer be possible.

### NOTICE

#### Not replacing broken hard disk

If you do not replace a broken disk in time and another disk fails in the meantime, your data may be unrecoverable.

**Replace a broken hard disk as soon as possible.**



Before replacing a hard disk you have to gather the log files of the RAID controller. If you know how to do this you may proceed on your own. If not, please contact the R&S DVS service department first.

In most cases you can find the broken disk by simply observing the LEDs on the hard disk carriers (see section “Hard Disk Array” on page 2-9). While performing continuous accesses to the data, it will be the one:

- no longer blinking (either continuously on or off),
- irregularly blinking compared to the other hard disks of the same disk set, or
- showing a hard disk or disk carrier related error like a lit up red alarm LED on a particular hard disk (see section “Hard Disk Array” on page 2-9).

Once the broken disk has been identified, you can replace it as described in section “Replacing a Hard Disk” on page 5-4.

**NOTICE****Replacing wrong hard disk**

Replacing the wrong hard disk, i.e. a good one instead of the broken one, may result in a total loss of data.

**If you are unsure about having detected the correct hard disk please contact the R&S DVS service department.**

### 5.1.3 Replacing a Hard Disk

As soon as the broken hard disk has been identified (see section “Identifying a Broken Hard Disk” on page 5-3), it can be replaced easily. The replacement of a broken hard disk can be divided into three steps:

1. Removing the hard disk from the system.
2. Replacing the hard disk.
3. Reassembling it into the system.

All steps are explained in the following.



Before replacing a hard disk you have to gather the log files of the RAID controller. If you know how to do this you may proceed on your own. If not, please contact the R&S DVS service department first.



## Step 1: Removing the Hard Disk

The hard disks that are accessible at the front of the system are connected to the system with the help of disk carriers. They can be removed easily, even when the system is running (hot-swappable).



For an overview of a disk carrier as well as further information about it see section “Hard Disk Array” on page 2-7 and section “System Disk Array” on page 2-12.

To remove a hard disk from the system perform the following:

1. If appropriate, stop all accesses to the hard disk array of your system, for example, by exiting the video system software and severing the network connections.
2. Fold down the faceplate of the system (see section “The Front of the System” on page 2-6).
3. Then, unlatch the disk carrier of the defective hard disk by pressing the opener of the disk carrier (1).



If you press the opener but it does not move and the lever does not come out of the disk carrier, it might still be locked. Use a hex key to turn the lock a quarter turn left in the direction of the open padlock symbol. Once you feel a slight resistance, the disk carrier should be unlocked.

This will cause the lever to come out of the disk carrier so that it protrudes from the rest of the disk carriers.

4. Take the lever and pull the hard disk carrier out of the hard disk array (2):

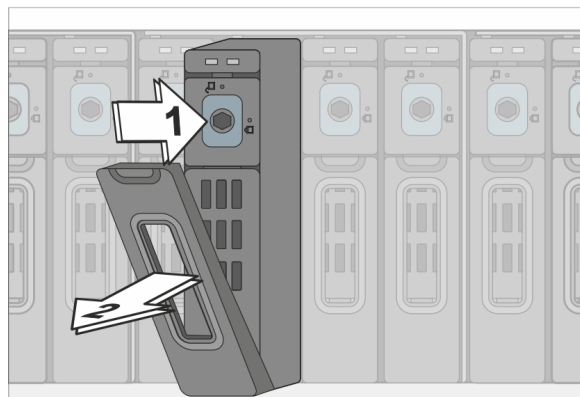

Figure 5-2: Pulling out the lever

This takes the hard disk installed in the disk carrier out of the system’s interfaces inside.

5. Once the interface connections inside the system are severed, you can pull the disk carrier out of the system. Now the hard disk is removed from the system and it has to be replaced in the next step.



## Step 2: Replacing the Hard Disk

To replace the hard disk do the following:

### NOTICE

#### Incorrect handling of the hard disks

Significant environmental changes, for example, altitude, voltage, temperature, shock, vibration, etc., can damage a hard disk.

#### Handle hard disks with great care.

1. Unscrew the screws that fix the hard disk to the disk carrier.
2. Exchange the broken disk with a new one and assemble it in the disk carrier with the screws.



It is best to use the same brand and type of hard disk again. Otherwise a loss of performance might occur.

After that the hard disk is replaced and the disk carrier with the new disk has to be reassembled in the system.

## Step 3: Reassembling the Hard Disk

After replacing the hard disk, the new disk carrier with the hard disk has to be reassembled in the system. For this perform the following:

1. Slide the disk carrier back into its shaft at the disk array.
2. Push the disk carrier completely back into the shaft by applying pressure to the disk carrier directly. Move it until you feel the resistance of the hard disk interface inside the system.
3. As the last step, push the lever and the disk carrier at the same time with caution but with raised force into the system. When the lever snaps back in place, the carrier and the hard disk should be mounted correctly in the R&S DVS system.



The disk carrier of the replaced disk should be level with the others of the array.

If required, you can lock the disk carrier with the hex key again.

Once the faceplate of the R&S DVS system is back in place, the replacement of the hard disk is finished. After several minutes the replaced hard disk will be automatically recognized by the system. Then the rebuild of the data will be initiated on its own. When the system has finished the rebuild, the R&S DVS system will be fully operational again.



**NOTICE**

**Accessing the hard disk while rebuild takes place**

Rebuild time depends on the load of the system. During a rebuild the performance of the system will be affected and real-time processes may not be possible.

**It is recommended to avoid accesses or to at least to restrict accesses to the disk array during this time, otherwise it may take considerably longer.**



## 5.2 Fan Maintenance

This section describes what to do if a fan failure takes place.

When a fan failure occurs, you will be notified by a lit alarm LED within the operation items at the front of the system (see section “Operation Items” on page 2-8) which will extinguish when you replace the broken fan. Additionally, you will be informed via e-mail notification, if your server is configured appropriately.



For further details about what to do in case of a hardware malfunction or an alarm, please refer to section “Troubleshooting” on page A-2.

You have to do the following to exchange the failed fan:

1. Observe the fans and memorize the failed one (the fan not revolving is the broken one).
2. Lift the handle of the broken fan (1) so that it protrudes from the rest of the fan module.
3. Take hold of the handle and unlock the respective fan module by pressing the unlocking device with your thumb to the right (2).
4. With the locking mechanism released, pull the fan module out of the system (3).

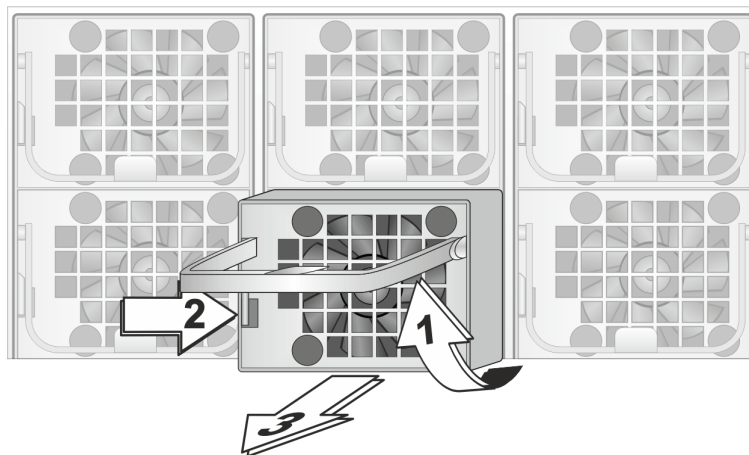

Figure 5-3: Removal of fan module

This will sever the connection of the fan to the system.

### DANGER

#### High voltages

The system you are working on operates with voltages that can be hazardous to your health.

**Do not reach inside the system when removing a power supply unit or when the unit is out of the system.**



5. Take the new fan module at its handle and slide it back into its shaft in the fan area.

**NOTICE**

**Other spare parts**

Others than the original manufacturer spare parts might damage your system.

**Only use original manufacturer spare parts.**

6. Re-insert the new fan module into the system by pushing it completely back into the shaft and folding down the handle again.



See to it that the fan module plugs properly into the system's fan interface and that, when completely inserted, the locking mechanism snaps back into its locked position to the left side of the handle.

With the last step finished you have successfully replaced the defective fan module. Once the system is turned on, no alarm LED should be lit up anymore.



## 5.3 Power Supply Maintenance

The redundant power supply provides the system with power. It is a reliable and enduring part of the system because it consists of two independent power supply units. Even if one fails, the other will still offer enough power to keep the system working.

### NOTICE

#### Second power supply failure

The system can be operated with one power supply unit out of order. However, if another one fails, a continued operation of the system cannot be guaranteed.

**It is recommended to change a failed power supply unit immediately.**

When a power supply unit failure occurs, you will be notified by the lit alarm LED within the operation items and the sounding of an alarm buzzer of the system. Additionally, you will be informed via e-mail notification, if your server is configured appropriately.



An alarm can be caused by a number of reasons. For example, an extinguished LED at a power supply unit can mean a standby mode, too. Please refer to section "Troubleshooting" on page A-2 first for further details about what to do in case of an alarm.

When operating the R&S DVS system, it is recommended to check the state of the alarm LED (see section "Operation Items" on page 2-8) at regular intervals.

Each power supply unit in the R&S DVS system is hot-swappable, so you can safely replace it with the system running. Follow these steps to replace a power supply unit:



For an overview of a power supply unit see section "Power Supply" on page 2-19.

1. Take a look at the power supply at the rear of the system and examine the LEDs of the units. The LED of the malfunctioning power supply unit should be extinguished.
2. Next unplug the power cord from this power supply unit.
3. Take the handle of the respective unit and press the unit's latch to the right to unlock it.
4. Then pull the unit at its handle out of the power supply.

**DANGER****High voltages**

The system you are working on operates with voltages that can be hazardous to your health.

**Do not reach inside the system when removing a power supply unit or when the unit is out of the system.**

5. Change the power supply unit against a new and operable one.
6. Slide the new unit into the power supply until it clicks into place.

**NOTICE****Other spare parts**

Others than the original manufacturer spare parts might damage your system.

**Only use original manufacturer spare parts.**



When completely inserted please observe that the latch is truly in place and locking the unit.

7. Connect the power source (power cord) to the newly installed power supply unit.
  8. After that check the LED indicating the status of the power supply unit: If it is lit up in green, the unit is working properly.
- With this the power supply unit has been replaced successfully.



## 5.4 Opening and Closing the Casing

Sometimes, for particular operational reasons, it is required to open the system's casing and to close it after having finished the intended work. Both tasks will be explained in this section.



All items that may be replaced in case of a failure can be accessed from the outside.

For this reason, opening the casing is only necessary in exceptions.

### 5.4.1 Opening the Casing

To open the casing of the R&S DVS system perform the following:



#### High voltages

The system you are working on operates with voltages that can be hazardous to your health.

**Never work on the system or access its interior with the power cable(s) being plugged in. Make sure the power supply is disconnected from the components you intend to work on.**



The system must be operated only with the chassis' cover installed to ensure proper cooling.

1. Shut down the system as described in section "Shutting Down the System" on page 4-2.
2. Disconnect all power cords from the system.
3. Unscrew the three screws at the rear of the system (1) and move the cover towards the rear of the system (2).

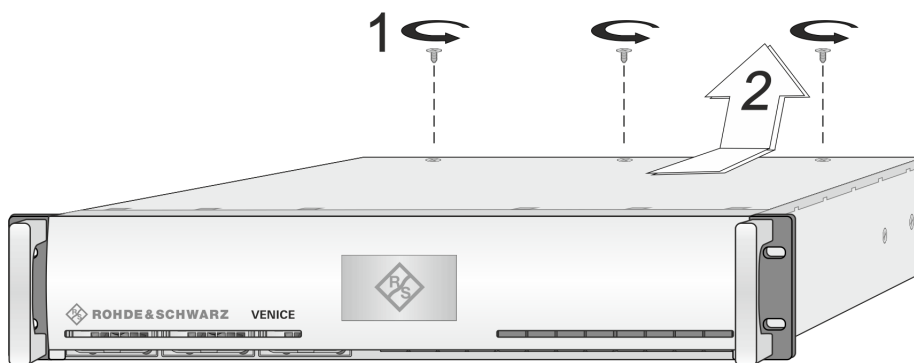

Figure 5-4: Removal of the cover of the casing

Once the cover is slid backward, it can be taken off the system.





## 5.4.2 Closing the Casing

After finishing your task at hand you have to close the casing of the R&S DVS system again. For this perform the following:

1. Simply put the cover back on and slide it towards the front into place until it locks.
  2. Tighten the three screws at the rear of the system.
  3. Afterwards reconnect the power cords.
- With this the task of closing the casing is finished and you can turn the system back on at any time.



## 5.5 Removal of the Faceplate

The faceplate of the system can be removed, for example, for transports. For this perform the following:

### NOTICE

#### Removing the faceplate

When operating the system without faceplate, electromagnetic compatibility might be the consequence.

**The system must be operated only with the faceplate installed to ensure electromagnetic compatibility.**

1. Fold down the faceplate of the system (see section “The Front of the System” on page 2-6).
2. Then pull the faceplate as far as its hinge brackets are pulled out of their guide rails up to the anchoring element. This is indicated in the following figure:

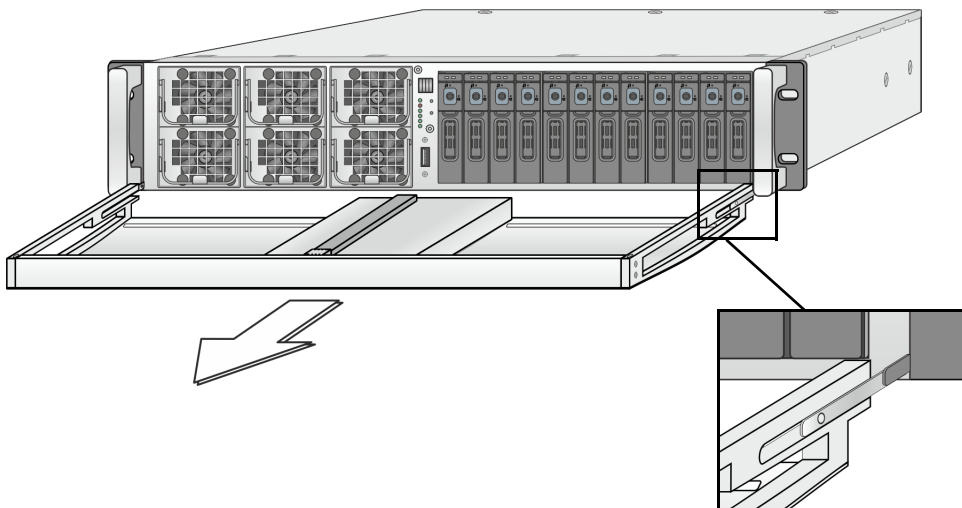

Figure 5-5: Removing the hinge brackets

The hinge brackets will be loosened so that they can be removed from their holders at the rack-mount ears. Afterwards the faceplate can be taken off with its hinge brackets.



To reassemble the faceplate reverse the above stated steps.

## 5.6 Backup or Recovery of the System Disk

The R&S DVS system provides internally a USB flash drive that can be used to back up or restore the operating system on the system hard disk. With it you can, for example, set the system disk back to its manufacturing state. Once selected as a boot device, it will launch a Live Linux which in turn will either back up or restore the system hard disk. The following sections describe how to create a backup image or perform a recovery of the system disk.

### 5.6.1 Creating a Backup Image of the System Disk

The following describes the steps to make a backup image of the system hard disk and save it to the internal USB flash drive:

#### NOTICE

#### Selecting wrong source device

For example, selecting the wrong source device could lead to a full storage space and a termination of the process.

**Do not execute any commands if you are not sure about the correct source and target device.**



To complete the loading of the DVS Rescue environment some user entries are required. For this follow the instructions given on the screen.

The loading of the environment and the recovery process itself will both try to initialize hardware that may not be present on your system. Any error messages displayed during loading/initialization, e.g. `Failed` or `Warning`, can be disregarded. The recovery process should work nonetheless.

The storage space on the USB is limited. The number of backup images that can be stored on the drive, besides the R&S DVS recovery image ex factory available, depends on the size of the image files. If the process fails, the storage drive may be full. However, an already created image can be overwritten when assigning the same name to it.

1. If appropriate, disconnect all Fibre Channel cables and all externally connected storage devices from the system.
2. Turn on or restart the R&S DVS system and at the indicated moment during start-up press [F4] on your keyboard to enter the boot menu.
3. Once the boot menu is displayed on the screen, select the internally installed USB flash drive as the boot device and then press [Enter] on your keyboard.

With this the target device has been selected. The system will now boot from the internal USB and you will see a window on the screen where you can select the DVS Rescue environment for loading:



4. Select `DVS Rescue` and press `[Enter]` on your keyboard.



If you do not perform any action, `DVS Rescue` will be loaded automatically after 30 seconds.

5. Once the loading has finished, you will see the `DVS Rescue` script with its options on the screen. Your display should look similar to the following:

```
--- DVS Rescue ---  
  
1 - Backup on internal USB device  
2 - Restore from internal USB device  
3 - Reboot the system  
4 - Poweroff the system  
  
0 - Exit
```

Enter selection:

6. To make a backup image of your system disk and save it to the internal USB, press `[1]` and then `[Enter]` on your keyboard. Afterwards a list of possible source devices will be detailed on the screen. In `VENICE 2U` the system device normally will be `'sda'`, but on special systems it may also be `'sdb'`, `'sdc'`, etc.



Ex factory the `R&S DVS` system will be delivered with `'sda'` as the default system disk. If other configurations have been made later or on customer request, this may be different.

### NOTICE

#### Selecting wrong source device

Selecting the wrong source device may lead to an unwanted configuration and malfunctions when the system is operating.

**Continue with the following steps only, when you are able to identify the correct source device.**

7. Enter the name of the system disk in the designated line. Just type in `sda` (in other cases `sdb` or `sdc`) and press `[Enter]` on your keyboard.

The system will now ask you to enter the image name for the backup image to be saved to the USB. By entering the name of an already existing backup image you can overwrite it.

8. Type in the name of the image you want to save to the USB for a later recovery. To confirm your entry press `[Enter]` on your keyboard.

The system will ask you to confirm your selection and whether you want to continue:



9. To start the backup process type in `y` for 'yes' and press [Enter] on your keyboard.



To abort the process at this point enter `n` for 'no' and press [Enter] on your keyboard. You will be redirected to the DVS Rescue script.

After starting the process its termination is not possible anymore.

The program will now start the backup process. Its progress will be indicated on the screen.



The backup process may take some time.

If during the process the screen turns black, press [Space] to get it back again.

When the system has finished the backup process, you will be notified about this. Then after pressing [Enter] on your keyboard, you will be redirected to the DVS Rescue script once more where you can choose, for example, 'reboot' or 'poweroff' to restart or turn off the system.

## 5.6.2 Restoring the System Disk

The following describes the steps to make a recovery of the system hard disk:

### NOTICE

#### Selecting wrong target device

For example, selecting the wrong target device can lead to a total loss of data.

**Do not execute any commands if you are not sure about the correct source and target device.**



To complete the loading of the DVS Rescue environment some user entries are required. For this follow the instructions given on the screen.

The loading of the environment and the recovery process itself will both try to initialize hardware that may not be present on your system. Any error messages displayed during loading/initialization, e.g. `Failed` or `Warning`, can be disregarded. The recovery process should work nonetheless.

Please contact the R&S DVS service department if you are not sure whether you are able to identify the correct target device.

1. If appropriate, disconnect all Fibre Channel cables and all externally connected storage devices from the system.
2. Turn on or restart the R&S DVS system and at the indicated moment during start-up press [F4] on your keyboard to enter the boot menu.



3. Once the boot menu is displayed on the screen, select the internally installed USB flash drive as the boot device and then press [Enter] on your keyboard.

The system will now boot from the internal USB and you will see a window on the screen where you can select the DVS Rescue environment for loading:

4. Select DVS Rescue and press [Enter] on your keyboard.



If you do not perform any action, DVS Rescue will be loaded automatically after 30 seconds.

Once the loading has finished, you will see the DVS Rescue script with its options on the screen. Your display should look similar to the following:

```
--- DVS Rescue ---

1 - Backup on internal USB device
2 - Restore from internal USB device
3 - Reboot the system
4 - Poweroff the system

0 - Exit

Enter selection:
```

5. To restore your system disk from the internal USB, press [2] and then [Enter] on your keyboard. Afterwards a list of possible target devices will be detailed on the screen. In a VENICE 2U the system device normally will be 'sda', but on special systems it may also be 'sdb', 'sdc', etc.



Ex factory the R&S DVS system will be delivered with 'sda' as the default system disk. If other configurations have been made later or on customer request, this may be different.

**NOTICE****Overwriting all data**

A recovery will overwrite all your data.

**Continue with the following steps only, when you are able to identify the correct target device.**

The system will ask you to enter the system device:

6. Enter the name of the system disk in the designated line. Just type in `sda` (in other cases `sdb` or `sdc`) and press [Enter] on your keyboard.

A further list of possible source images will be detailed on the screen. If there is only the R&S DVS recovery image on the USB flash drive, this one will be listed. If there are several images, all will be displayed.



7. Select the image you want to use for the recovery by pressing the arrow keys on your keyboard. Normally, it provides the serial number of the R&S DVS system in its name. To confirm your choice press [Enter] on your keyboard.

The system will ask you to confirm your selection and whether you want to continue:

8. To start the recovery process type in `y` for 'yes' and press [Enter] on your keyboard.



To abort the process at this point enter `n` for 'no' and press [Enter] on your keyboard. You will be redirected to the DVS Rescue script.

After starting the process its termination is not possible anymore.

The program will now start the recovery process. Its progress will be indicated on the screen.



The recovery process may take some time.

If during the process the screen turns black, press [Space] to get it back again.

When the system has finished the recovery process, you will be notified about this. Then after pressing [Enter] on your keyboard, you will be redirected to the DVS Rescue script once more where you can choose, for example, 'reboot' or 'poweroff' to restart or turn off the system. The next time the R&S DVS system is started, it will load the restored operating system.

## Maintenance

▶ Backup or Recovery of the System Disk

---







# Appendix

## Contents

Troubleshooting .....	A-2
Technical Data .....	A-4
General Technical Data .....	A-4
Dimensions .....	A-5
Video Rasters .....	A-6
Signal In- and Outputs .....	A-7
Packing Instructions .....	A-10
Conformity Declarations .....	A-12
RoHS Compliance .....	A-12
EC Declaration of Conformity (CE Marking) .....	A-12
FCC Compliance Statement .....	A-13
Korea Certification .....	A-14



## A.1 Troubleshooting

The table below lists some errors that may occur during the operation of the R&S DVS system and details how to resolve them. If you experience trouble that cannot be resolved with the solutions described here or in chapter “Maintenance” on page 5-1, please contact your local vendor or R&S DVS directly.

**Table A-1: Troubleshooting for the VENICE 2U system**

Error	Cause	Solution
<p>Accesses to the main storage are slow. <i>AND/OR</i></p> <p>Drops occurred during playout/capture.</p>	The data storage is too full.	It is recommended to use only 85% of the overall hard disk capacity to ensure realtime capability. If the storage is too full, delete some of your data.
	Configurations of the system have been altered.	Contact the R&S DVS service department.
	One or more hard disks of the hard disk array are worn.	Try to identify the worn disk and replace it as described in section “Hard Disk Maintenance” on page 5-2.
	A RAID controller is defective.	If you can rule out the above mentioned causes, a RAID controller may be defective. Please contact the R&S DVS service department.
<p>An alarm is sounded and the alarm LED within the operation items is lit. <i>AND/OR</i></p> <p>You received an e-mail notification according to your settings.</p>	One of the power supply units has been disconnected from power during operation.	Check the LEDs of the power supply units. If one is extinguished, this unit may be disconnected from power. Examine the power cord of the unit. See to it that it is in good technical order, correctly plugged in at both ends and that the mains current is operating properly.
	One of the power supply units has failed.	Check the LEDs of the power supply units. If one is extinguished and you can rule out the above mentioned cause, a power supply unit has failed. Replace the broken unit as described in section “Power Supply Maintenance” on page 5-10.

[Continued on the next page]

Error	Cause	Solution
	A fan has failed.	Check the LEDs of the power supply units. If all are green, shut down the system (see section “Shutting Down the System” on page 4-2) and check whether a fan has failed (see section “Removal of the Faceplate” on page 5-14). If necessary replace the broken module as described in the same section.
	The system is overheated.	If you can rule out the above mentioned causes, the alarm must be due to overheating. See to it that the ambient temperature at the front of the system does not exceed the operating temperature specified in section “Technical Data” on page A-4. If the temperature is within the range, check the ventilation holes of the system and free them from all obstructions (e.g. dust). In case the problem persists, contact the R&S DVS service department.
<p>An alarm is sounded and the alarm LED within the operation items is off (sometimes while the LED disk error can be lit up in red).</p> <p><i>OR</i></p> <p>At start-up the system is not able to initialize a disk set.</p>	A hard disk or a hard disk carrier got loose/jammed (e.g. after transport) or is not mounted correctly.	Shut down the system as described in section “Shutting Down the System” on page 4-2. Then perform the following: Pull all disk carriers partially out of the chassis and afterwards install them again. See to it that they are pulled out and reassembled correctly as described in section “Replacing a Hard Disk” on page 5-4. After that start the system again.
	A hard disk of the hard disk array is defective.	Replace the defective disk as explained in section “Hard Disk Maintenance” on page 5-2.
	The RAID controller is defective.	If you can rule out the above mentioned causes, a RAID controller may be defective. Please contact the R&S DVS service department.



## A.2 Technical Data

This section provides technical data of VENICE 2U.



When installing the R&S DVS system in a rack, take care that warmed up air is conducted to the rear of the rack and properly vented away.

### A.2.1 General Technical Data

The general technical data of VENICE 2U are as follows (measured with VENICE 2U in four-channel variant (2 × E5-2690@2.90 GHz, 32 GB RAM, 12 × ST300MM0026, 1 × QLE2562):

Chassis weight	Approx. 21 kg
Chassis weight with drives	Approx. 23 kg
Environment (also during transport)	No exposure to heat No exposure to strong electric or magnetic fields No vibrations/shocks allowed
Operating temperature	Maximum: 10 – 30 °C (50 – 86 °F) Optimum: 15 – 25 °C (59 – 77 °F)
Storage temperature	0 – 50 °C (32 – 122 °F)
Humidity	10 % to 80 % RH @ 30 °C, non-condensing
Non-operating humidity	Up to 85 % RH @ 30 °C, non-condensing
Air	Dust-free
Power consumption	899 W max. input power 618 W typ. input power 336 W idle power
Input power requirements	100 – 240 V @ 47 – 63 Hz
Max. Amperage	3,9 A @ 230 V

## A.2.2 Dimensions

The following figure shows the dimensions of the R&S DVS system. The drawing already includes some space for connectors and plugs that can protrude from the rear ('plug safety' ( $l$  minus  $j$ ), usually plus 150 mm). However, this amount of space depends on the type of connectors used.

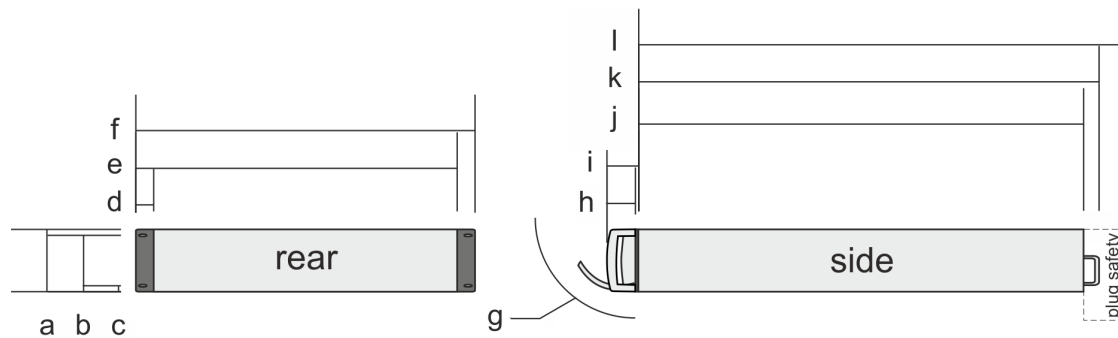

Figure A-1: Measured dimensions

a	88 mm	g	105 mm
b	66 mm	h	40 mm
c	22 mm	i	43 mm
d	25 mm	j	630 mm
e	455 mm	k	655 mm
f	480 mm	l	780 mm



## A.3 Video Rasters

The following table shows some of the supported video rasters. All frequencies indicate the frame rate.



Some rasters are available as optional features only. The availability of rasters depends on the selected file format and/or codec.

Some rasters are not available for all VENICE 2U hardware variants. For further information about VENICE 2U and available options see section “R&S®VENICE 2U Models” on page 2-2.

**Table A-2: Supported video rasters**

Raster	Total lines per frame	x size	y size	Aspect ratio
525i /29.97 (NTSC)	525	720	486	4:3
625i /25 (PAL)	625	720	576	4:3
720p /23.976/24/25/29.97/30 /50/59.94/60	750	1280	720	16:9
1080i /23.976/24/25/29.97/30	1125	1920	1080	16:9
1080p <sup>1</sup> /23.976/24/25/29.97/30 /47.952/48/50/59.94/60	1125	1920	1080	16:9
1080psF /23.976/24/25/29.97 /30	1125	1920	1080	16:9
2048p /23.976/24/25	1125	2048	1080	2:1
2048psF /23.976/24/25	1125	2048	1080	2:1
2048psF /23.976/24/25	1600	2048	1556	4:3

1) Frequencies higher 30 Hz are available on the HDMI output only.

## A.4 Signal In- and Outputs

This section provides pin-out information about some of the connectors provided by the VENICE 2U system. If some of the connectors given below are not provided by a VENICE 2U model, this will be indicated.

### High-Definition Multimedia Interface (HDMI Connector, only optional for VENICE 2U)

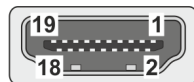

(external view;  
female on interface, male on cable)

Pin No.	Signal	Pin No.	Signal
1	TMDS Data 2 (+)	11	TMDS CLK GND
2	TMDS Data 2 GND	12	TMDS CLK (-)
3	TMDS Data 2 (-)	13	CEC
4	TMDS Data 1 (+)	14	– (reserved)
5	TMDS Data 1 GND	15	SCL
6	TMDS Data 1 (-)	16	SDA
7	TMDS Data 0 (+)	17	DDC CEC GND
8	TMDS Data 0 GND	18	+5V
9	TMDS Data 0 (-)	19	Hot Plug Detect
10	TMDS CLK (+)		



## Digital Audio (25-Pin D-Sub Connector)

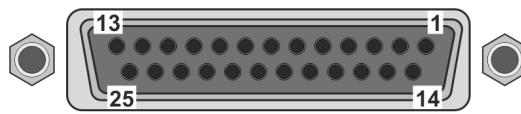

(external view;  
 female on interface, male on cable)

Table A-3: Digital Audio 1-8 (Tascam assignment)

Pin No.	Signal	Pin No.	Signal
1	Audio OUT CH 7/8 (+)	14	Audio OUT CH 7/8 (-)
2	GND	15	Audio OUT CH 5/6 (+)
3	Audio OUT CH 5/6 (-)	16	GND
4	Audio OUT CH 3/4 (+)	17	Audio OUT CH 3/4 (-)
5	GND	18	Audio OUT CH 1/2 (+)
6	Audio OUT CH 1/2 (-)	19	GND
7	Audio IN CH 7/8 (+)	20	Audio IN CH 7/8 (-)
8	GND	21	Audio IN CH 5/6 (+)
9	Audio IN CH 5/6 (-)	22	GND
10	Audio IN CH 3/4 (+)	23	Audio IN CH 3/4 (-)
11	GND	24	Audio IN CH 1/2 (+)
12	Audio IN CH 1/2 (-)	25	GND
13	–		



## RS-422 In and RS-422 Out (9-Pin D-Sub Connector)

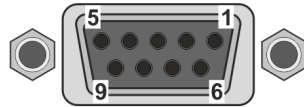

(external view;  
female on interface, male on cable)

RS-422 In		RS-422 Out	
Pin No.	Signal	Pin No.	Signal
1	–	1	–
2	TX_D_CON (-)	2	RX_C_CON (-)
3	RX_D_CON (+)	3	TX_C_CON (+)
4	GND	4	GND
5	–	5	–
6	GND	6	GND
7	TX_D_CON (+)	7	RX_C_CON (+)
8	RX_D_CON (-)	8	TX_C_CON (-)
9	–	9	–

These connectors will be switched between 'RS-422 In' and 'RS-422 Out' by the software automatically depending on the selected operation mode and depending on the VENICE 2U options you have selected (see section "R&S®VENICE 2U Models" on page 2-2).

For RS-422 control R&S DVS systems support the standard industrial 9-pin protocol.



## A.5 Packing Instructions

The following describes the best way to pack an R&S DVS system.

### NOTICE

#### Incorrect packaging

The warranty will be void if you do not transport the R&S DVS device in the original packing.

**You have to keep the original packing and use it in case of transportation.**

**In any other case, if you do not have the original packing anymore, use a similar structured packing for transportation. R&S DVS cannot be held liable for damages due to transportation.**



Fragile. Avoid shocks or vibrations. For longer distances use a lifting truck.



Keep dry.

Figure 1:

Wrap video system in foil:

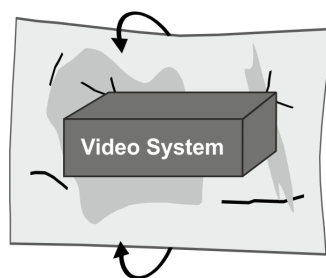
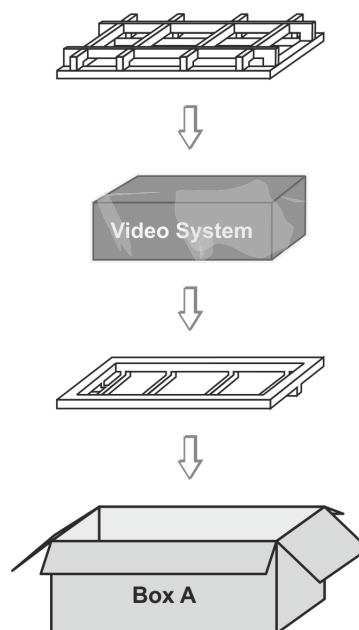
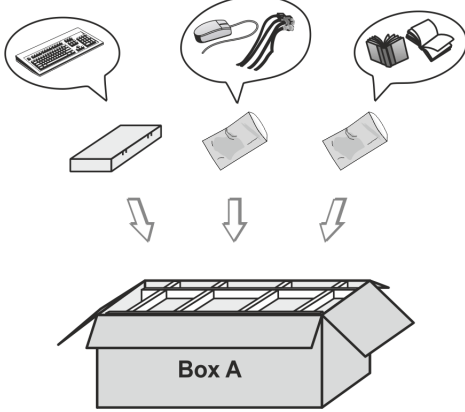
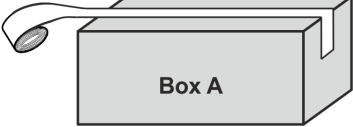
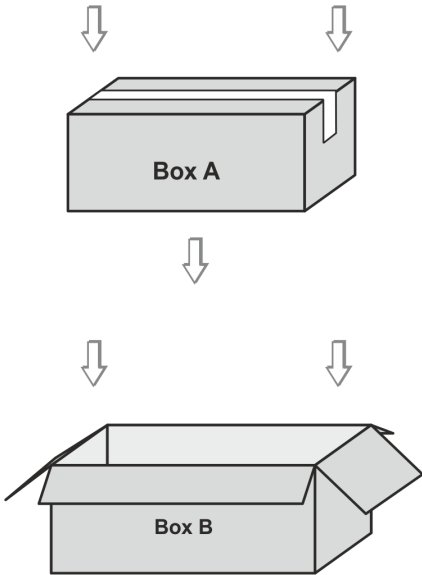
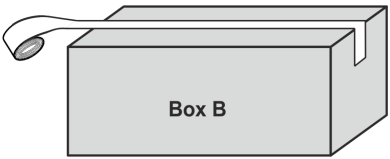

Figure 2:

Pack video system in box A with foam:



<p><i>Figure 3:</i></p> <p>Pack accessories:</p> 	<p><i>Figure 4:</i></p> <p>Close box A:</p> 
<p><i>Figure 5:</i></p> <p>Pack box A in box B:</p> 	<p><i>Figure 6:</i></p> <p>Close box B:</p> 



## A.6 Conformity Declarations

VENICE 2U has been tested according to the applying national and international directives and regulations. The following states further information about the compliances and conformities.

### A.6.1 RoHS Compliance

The EU directive 2002/95/EC 'Restriction of Hazardous Substances (RoHS)' prohibits the use of certain substances in electrical and electronic equipment. The VENICE 2U devices are manufactured in compliance with this directive.

### A.6.2 EC Declaration of Conformity (CE Marking)

Rohde & Schwarz DVS GmbH herewith declares that the following product according to the provisions of the mentioned EC Directives – including their relevant revisions at the time of this declaration – is in conformity with the detailed standards or other normative documents:

<b>VENICE 2U</b>	EC Directives:
	<ul style="list-style-type: none"><li>▪ EMC Directive 2004/108/EC</li><li>▪ Low-Voltage Directive 2006/95/EC</li></ul>
	Applied Harmonized Standards:
	<ul style="list-style-type: none"><li>▪ EN 55022</li><li>▪ CISPR 22</li><li>▪ AS/NZS CISPR 22</li><li>▪ EN 61000-3-2</li><li>▪ EN 61000-3-3</li><li>▪ EN 55024</li><li>▪ IEC 61000-4-2</li><li>▪ IEC 61000-4-3</li><li>▪ IEC 61000-4-4</li><li>▪ IEC 61000-4-5</li><li>▪ IEC 61000-4-6</li><li>▪ IEC 61000-4-8</li><li>▪ IEC 61000-4-11</li></ul>

### A.6.3 FCC Compliance Statement

Rohde & Schwarz DVS GmbH herewith declares that the following equipment has been tested according to the applying valid FCC regulations:

- VENICE 2U

#### FCC Notice

This equipment has been tested and found to comply with the limits for a Class A digital device, pursuant to Part 15 of the FCC Rules, the standards of ICES-003:2012 Issue 5, Class A and ANSI C63.4-2009. These limits are designed to provide reasonable protection against harmful interference when the equipment is operated in a commercial environment. This equipment generates, uses, and can radiate radio frequency energy and, if not installed and used in accordance with the instruction manual, may cause harmful interference to radio communications. Operation of this equipment in a residential area is likely to cause harmful interference in which case the user will be required to correct the interference at his own expense.

**Note:** Connecting this device to peripheral devices that do not comply with Class A requirements or using an unshielded peripheral data cable could also result in harmful interference to radio or television reception. The user is cautioned that any changes or modifications not expressly approved by the party responsible for compliance could void the user's authority to operate this equipment. To ensure that the use of this product does not contribute to interference, it is necessary to use shielded I/O cables.



## A.6.4 Korea Certification

The KC (Korea Certification) mark applies for all types of electronic products and unifies several existing certification marks. The KC Mark is required for all new products subject to compulsory certification under laws and ordinances pertaining to safety, health, environment and quality. Rohde & Schwarz DVS GmbH herewith declares that the following equipment has been tested according to the applying valid KC regulations:

- VENICE 2U



이 기기는 업무용(A급) 전자파  
적합기기로서 판매자 또는  
사용자는 이 점을 주의하시기  
바라며, 가정외의 지역에서  
사용하는 것을 목적으로 합니다.

*Figure A-2: KC (Korea Certification)*

# Index

## Numerics

- 3 Gbit/s SDI ..... 2-15, 2-16, 2-17, 2-14
- 9-pin D-Sub connector pin-out
  - RS-422 In ..... 2-19, A-9
  - RS-422 Out ..... 2-19, A-9
- 1 Gbit/s Ethernet ..... 2-21
- 10 Gbit/s Ethernet ..... 2-21
- 25-pin D-Sub connector pin-out ..... A-8

## A

- activity of hard disks ..... 2-10
- alarm ..... A-2
  - buzzer ..... 1-8
  - fan ..... 5-8
  - hard disk failure ..... 5-3, A-3
  - LED ..... 2-8, 5-8, 5-10, A-2
  - overheating ..... A-3
  - power supply unit failure ..... 5-10
  - RAID controller ..... 5-3, A-3
- ASCII encoding of English capital letters .  
2-26
- ATX connector panel ..... 2-14, 2-20
- audio
  - digital (AES/EBU) ..... 2-4, 2-17
  - per video channel ..... 2-17
  - pin-out ..... A-8
  - XLR connectors ..... 2-4, 2-17

## B

- backup image of the system disk ..... 5-15
- battery backup ..... 2-9, 2-24
- BIOS ..... 1-7
- breakout cable (digital audio) ..... 2-17

## C

- carrier (hard disk) ..... 2-10
- casing ..... 1-4
  - close ..... 5-13
  - open ..... 5-12

- closing of casing ..... 5-13
- color modes ..... 2-4, 2-15
- COM port ..... 2-21
- conformity declaration ..... 1-7, A-12
- connectors ..... 2-13
  - ATX connector panel ..... 2-14, 2-20
  - labeling ..... 2-14
  - main connector panel ..... 2-13, 2-16
  - naming conventions ..... 2-14
  - slot panels ..... 2-14, 2-22
  - USB ..... 2-7, 2-8, 2-9, 2-21
- contact surface ..... 2-9
- conventions
  - naming of connectors ..... 2-14
  - screenshots ..... 1-3
- conventions (typographical) ..... 1-1

## D

- data loss ..... 2-9, 2-24
- data protection ..... 5-2
- DB-9 connector ..... 2-19
  - RS-422 In ..... A-9
  - RS-422 Out ..... A-9
- DB-25 connector ..... 2-17, A-8
- DB-9 ..... 2-19
- declaration of conformity ..... 1-7, A-12
- digital audio (breakout cable) ..... 2-17
- Digital Audio 1-8 ..... A-8
  - Ch. 1 ..... 2-17
  - Ch. 2 ..... 2-17
  - Ch. 3 ..... 2-18
  - Ch. 4 ..... 2-18
- digital video ..... 2-16, 2-17
  - in- and outputs ..... 2-14
- dimensions ..... A-5
- disk carrier ..... 2-10, 5-5
  - lock ..... 2-11
  - unlock ..... 2-11
- disk power LED (disk carrier) ..... 2-10
- disk set (RAID pack) ..... 5-2
- dual link ..... 2-14, 2-16, 2-17
- DVS Rescue ..... 5-16, 5-18

**E**

e-mail notification ..... 2-8, A-2  
 fan failure ..... 5-8  
 power supply failure ..... 5-10  
 environmental conditions ..... 1-5, A-4  
 Ethernet ..... 2-21  
 1 Gbit/s ..... 2-21  
 10 Gbit/s ..... 2-21  
 exchanging  
 fan ..... 5-8  
 hard disk ..... 5-4  
 power supply unit ..... 5-10

**F**

faceplate ..... 2-6  
 fold down ..... 2-6  
 R&S DVS logo ..... 2-6, 2-9  
 removal ..... 5-14  
 fan  
 area ..... 2-6, 2-7  
 failure ..... 5-8  
 fan module ..... 2-11, 5-8  
 exchange ..... 5-8  
 fan ..... 2-12  
 handle ..... 2-12, 5-8  
 lock ..... 5-9  
 status of the unit ..... 2-8, 5-8  
 unlocking device ..... 2-12, 5-8  
 fast shut down ..... 4-3  
 format  
 file ..... 2-5  
 video ..... 2-5  
 front overview ..... 2-6

**G**

graphics card ..... 2-22  
 guarantee ..... 1-6

**H**

handle  
 fan module ..... 2-12  
 power supply ..... 2-20  
 hard disk array (overview) ..... 2-7, 2-9  
 hard disk(s) ..... 2-9  
 activity ..... 2-10  
 assembly ..... 5-6  
 disk error LED ..... 2-10  
 disk power LED ..... 2-10

disk set (RAID pack) ..... 5-2  
 failure ..... 2-10, 5-2  
 rebuilding failed disk ..... 5-6  
 removal ..... 5-5  
 replace ..... 5-4, 5-6  
 status ..... 2-10  
 HDMI (selection) ..... 2-15  
 HDMI connector  
 HDMI 1.3 ..... 2-18  
 HDMI 1.4a ..... 2-18  
 pin-out ..... A-7  
 hinge ..... 2-6  
 hinge bracket ..... 5-14

**I**

important notes ..... 1-6, 1-7  
 independent video channels ..... 2-14  
 installation  
 network ..... 3-3  
 instructions  
 operation ..... 4-2  
 packing ..... A-10  
 safety ..... 1-4  
 IPMI ..... 2-21

**K**

key channel ..... 2-14  
 keyboard ..... 3-2  
 Korea Certification ..... A-14  
 KVM ..... 2-21

**L**

labeling of connectors ..... 2-14  
 LAN ..... 2-7, 2-8, 2-21, 5-5  
 latch (power supply) ..... 2-20  
 LEDs  
 alarm ..... 2-8, 5-3, 5-8, 5-10, A-2  
 disc error ..... 2-10  
 disk power ..... 2-10  
 network ..... 2-8  
 power supply ..... 2-20, 5-10  
 lever (disk carrier) ..... 2-11  
 LTC ..... 2-17, 2-18  
 XLR connectors ..... 2-17, 2-18  
 LTC In 1/2 ..... 2-18  
 LTC In 3/4 ..... 2-18  
 LTC Out 1/2 ..... 2-17  
 LTC Out 3/4 ..... 2-17



## M

magnets .....2-6  
 main connector panel ..... 2-13, 2-16  
 main storage ..... 1-8, 2-7, 2-9, 5-2, A-2  
 metadata storage ..... 2-9, 5-2  
 Mini XLR connector ..... 2-4, 2-17, 2-18  
   LTC ..... 2-4, 2-17, 2-18  
 monitor ..... 2-22, 3-2  
 motherboard .....2-7  
 mouse .....3-2

## N

naming conventions (connectors) ....2-14  
 network  
   installation .....3-3  
 network connection .. 2-7, 2-8, 2-21, 5-5  
 notes (important) ..... 1-6, 1-7

## O

opener (disk carrier) .....2-10  
 opening of casing .....5-12  
 operation items ..... 2-6, 2-7, 2-8  
 overheating ..... A-3  
 overview  
   connectors .....2-13  
   fan area .....2-11  
   front .....2-6  
   hard disk array .....2-9  
   power supply units .....2-19  
   RAID .....5-2  
   rear .....2-13

## P

packing instructions ..... A-10  
 parity information (RAID) ..... 5-2, 5-3  
 pin-out  
   9-pin D-Sub connector ..... 2-19, A-9  
   25-pin D-Sub connector ..... A-8  
   audio ..... A-8  
   HDMI ..... A-7  
   RS-422 In ..... 2-19, A-9  
   RS-422 Out ..... 2-19, A-9  
 power .....2-9  
   on/off status .....2-6  
   switch ..... 2-9, 4-2  
 power cable socket .....2-20  
 power LED .....2-8  
 power supply .....2-13

handle .....2-20  
 latch .....2-20  
 LED .....2-20  
 overview of the units .....2-19  
 power cable socket .....2-20  
 status of unit .....2-19, 2-20  
 unit failure .....5-10  
 power supply unit  
   failure .....2-20  
   lock .....2-20  
 power switch .....2-9, 4-2  
 protocols (RS-422) ..... A-9

## Q

query the system .....2-25

## R

R&S DVS logo (faceplate) .....2-6, 2-9  
 RAID .....2-9, 5-2  
   controller ..... 2-24, 5-2, 5-3  
   disk set (RAID pack) .....5-2  
   overview .....5-2  
   parity information .....5-2, 5-3  
   rebuilding failed disk .....5-6  
 rear overview .....2-13  
 rebuilding failed disk .....5-6  
 Ref In 1/2 .....2-16  
 Ref In 3/4 .....2-16  
 reference input .....2-16  
 remote control .....2-16  
 removal of the faceplate .....5-14  
 replacing a hard disk .....5-4  
 reset button .....2-9  
 restoring the system disk .....5-17  
 RS-232 .....2-21  
 RS-422 .....2-16  
   Ch. 1 .....2-19  
   Ch. 2 .....2-19  
   Ch. 3 .....2-19  
   Ch. 4 .....2-19  
   control protocol ..... A-9  
   In pin-out ..... 2-19, A-9  
   Out pin-out ..... 2-19, A-9

## S

safety instructions ..... 1-4  
 SAS .....2-22  
 SDI (serial digital interface) .....2-16, 2-17  
   3 Gbit/s SDI .. 2-14, 2-15, 2-16, 2-17



- in- and outputs ..... 2-14
  - signal distribution ..... 2-15
  - SDI In
    - Ch. 1 ..... 2-17
    - Ch. 2 ..... 2-17
    - Ch. 3 ..... 2-17
    - Ch. 4 ..... 2-17
  - SDI Out
    - Ch. 1 ..... 2-16
    - Ch. 2 ..... 2-17
    - Ch. 3 ..... 2-17
    - Ch. 4 ..... 2-17
  - shutting down ..... 4-2
    - fast shut down ..... 4-3
  - Simple Network Management Protocol (SNMP) ..... 2-25
  - single link ..... 2-14, 2-16, 2-17
  - slot panel connectors ..... 2-14, 2-22
  - SNMP (Simple Network Management Protocol) ..... 2-25
  - specification(s) ..... 2-4
  - starting ..... 4-2
  - state of the system ..... 2-25
  - status
    - of disk power ..... 2-10
    - of fan ..... 5-8
    - of hard disks ..... 2-10
    - of power supply unit ..... 2-19, 2-20
    - of power-on/-off ..... 2-6
  - storage capacity ..... 1-8
  - stripe set ..... 5-2
  - system query ..... 2-25
  - system reset ..... 2-9
  - system/metadata HDD .... 2-7, 2-9, 2-24, 5-2
- T**
- target group ..... 1-1
- U**
- technical data
    - dimensions ..... A-5
    - general ..... A-4
  - transportation ..... 1-5, A-10
  - troubleshooting ..... A-2
  - typographical conventions ..... 1-1
- U**
- uncovered front of the system ..... 2-6
  - USB connectors ..... 2-7, 2-8, 2-9, 2-21
- V**
- VENICE
    - main storage 1-8, 2-7, 2-9, 5-2, A-2
    - shut down ..... 4-2
    - specifications ..... 2-4
    - start ..... 4-2
    - storage capacity ..... 1-8
    - system/metadata 2-7, 2-9, 2-24, 5-2
    - video raster ..... A-6
  - VGA ..... 2-21
  - video channel
    - audio ..... 2-17
    - SDI ..... 2-16, 2-17
    - specifications ..... 2-4
  - video channels (independent) ..... 2-14
  - video raster ..... 2-14, A-6
- W**
- warranty ..... 1-6
  - workflow ..... 3-3
- X**
- XLR connector (audio) ..... 2-4, 2-17